



Grid Solutions
a GE and Alstom joint venture

PROTECTION PRODUCT SOLUTIONS

MiCOM Agile P747

Numerical busbar protection

The P747 centralised numerical busbar protection provides complete protection for all voltage levels up to extra high voltage



MiCOM P747 3 box solution

CUSTOMER BENEFITS

- 4 zones & check zone protection
- Fast fault trip (typically 17 ms)
- Synchronous or sequential trip
- Adapted to all kinds of busbar configurations
- IEC 61850-8.1 compliant
- Redundant communications with zero downtime
- Can operate with different types of current transformers
- Programmable function keys, hotkeys and Tri-colour LEDs

The MiCOM Agile P747 offers security, speed and high sensitivity

Proven techniques and dynamic topology processing algorithms offer a combination of security, speed and high sensitivity.

EASY INTEGRATION INTO ANY SUBSTATION

With a typical operating time of 17 ms, the P747 protection is one of the fastest in its class. Moreover, the trips can be synchronous or sequential. Fully compatible with IEC 61850-8.1, Courier, DNP3.0 Over Ethernet, Modbus and IEC 103 protocols, the P747 is easily integrated into any substation system.

The substation replica processing algorithms ensure that the P747 adapts to the dynamically changing topology of the busbar, which can be displayed on any PC via the substation real time dynamic monitoring tool.

The MiCOM Agile P747 differential busbar protection provides a centralised 3-box architecture and is very simple to use: It does not need to be heavily engineered and facilitates easy operations and maintenance of busbars.

REDUNDANT COMMUNICATIONS

MiCOM Agile P40 series extends the IEC 61850-8-1 station bus to include Parallel Redundancy Protocol (PRP), which offers a vendor-interoperable solution to implement redundant communications. It has the advantage of taking zero time to recover from a failure, as parallel alternative paths are continually operative. This compares to 25 ms or more healing time for legacy techniques such as RSTP.

MiCOM P40 AGILE

Grid Solutions' philosophy is one of continuous improvement in our products and solutions. Our emphasis on communications in MiCOM products has become a focus which secures our leadership in digital substations. To mark this phase of evolution, the P40 Agile livery is now applied to the range. The P40 Agile is a mark of performance and quality, proudly available from Grid Solutions.



APPLICATION

MiCOM Agile P747 centralised numerical busbar protection has been designed to protect a wide range of busbar configurations:

- 3-box mode – one P747 per phase. (The units are totally independent and not linked to each other.)

The MiCOM Agile P747 can accommodate up to 4 zones plus check zone. Each box (per phase) can manage:

- 4 VTs (1 VT per zone), up to 18 CTs, 18 breakers and 72 isolators
- Up to 40 digital inputs and 128 virtual inputs
- Up to 32 digital outputs and 128 virtual outputs

The MiCOM Agile P747 is associated with each CT location, usually one per incomer/feeder and one or two for each bus coupler/bus section. The P747 acquires the analogue signals from the associated CT and the binary signals from the auxiliary contacts of the circuit-breakers and isolators.

The P747 also incorporates the main enhanced circuit-breaker failure logic together with additional protection functions (dead zone, overcurrent, etc...).

The P747 is particularly useful in double busbar with double bus coupler applications. It allows a high number of opto inputs, relay outputs, virtual inputs and virtual outputs to be used for communication exchanges between boxes via GOOSE messages in order to manage the complete substation scheme.

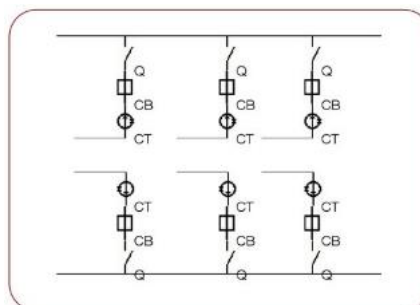
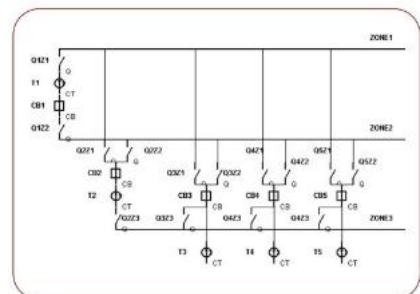
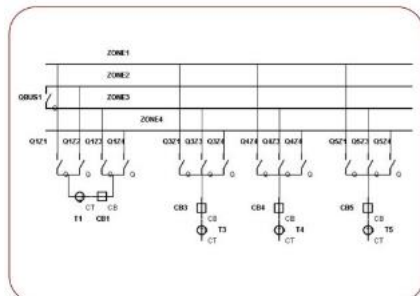
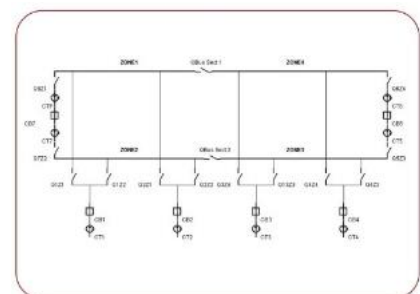
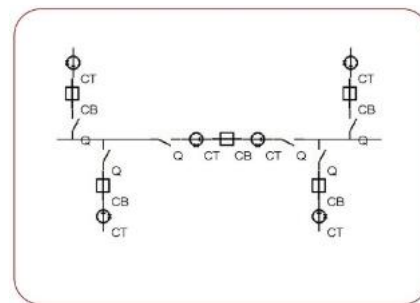

Topology scheme examples

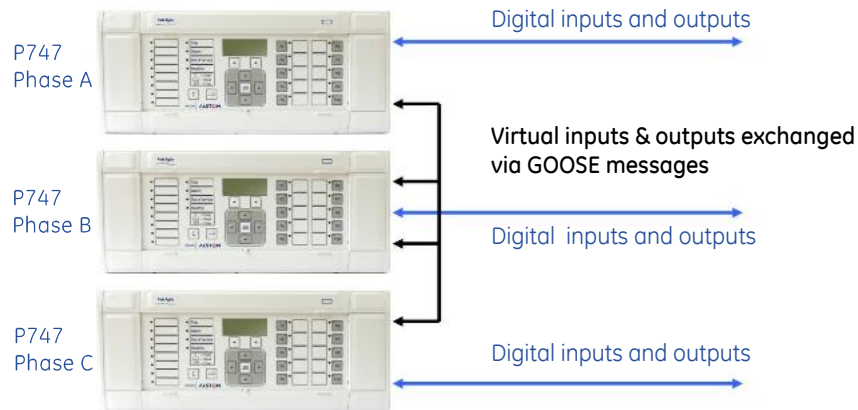

Typical MiCOM P747 Agile arrangement

Cost optimised to suit simple busbar configurations

Protection functions overview

ANSI	IEC 61850	Features	P747
87BB / P	PhsPDIF	Phase segregated biased current differential, high speed busbar protection	•
87CZ / P	CzPPDIF	Check zone segregated biased phase current differential, high speed busbar protection	•
50 / 51 / P	OcpPTOC	Phase overcurrent protection (2 stages)	•
27		Undervoltage check for 4 zones of protection (1 stage per zone)	•
50ST / P	DzpPhsPTOC	Dead zone phase protection (short zone between CTs and open CBs)	•
VTS		VT blocking scheme based on V<	•
50BF	RBRF	Breaker failure protection (LBB)	•
		ISL Isolator discrepancy alarm	•
	OptGGIO	Digital inputs	16 to 40*
	RlyGGIO	Output relays	16 to 32*
		Virtual digital inputs	128
		Virtual digital outputs	128
		Front communications port (RS232)	
		Rear communications port (Kbus/EIA(RS)485)	•
		Rear communications port (Ethernet) *	Option
		Time synchronisation port (IRIG-B) *	Option
	FnkGGIO	Function keys	10
	LedGGIO	Programmable tri-colour LEDs	18

* Refer to data sheet for model selection

MANAGEMENT FUNCTIONS

In addition to protection and control elements, the P747 provides a wide range of measurement, monitoring, post fault analysis and self-diagnostic features:

- Trip circuit supervision (using PSL)
- Online measurement
- Plant status monitoring
- 4 alternative settings groups
- Programmable logic (PSL)
- Sequence of event recording (SOE),
- Comprehensive fault records
- Comprehensive disturbance recording (waveform capture)
- User configurable function keys and hotkeys
- User configurable tri-colour LEDs
- Local and remote communications ports
- Time synchronisation
- Fully customisable menu texts
- Multi-level password protection
- Test facilities
- Power-up diagnostics and continuous self-monitoring of relay
- User friendly settings, analysis and monitoring software

FUNCTIONAL OVERVIEW

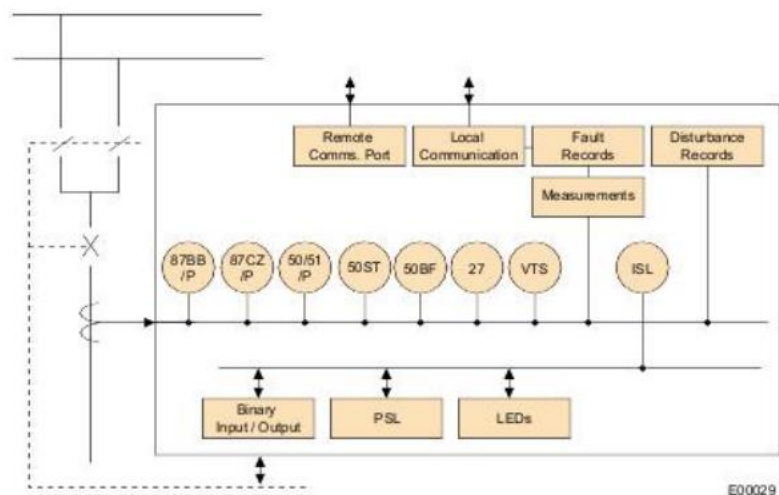

BUSBAR DIFFERENTIAL PROTECTION

The primary protection element of the P747 is the phase segregated biased current differential protection. The technique is based on the numerical application of Kirchoff's Law for the selective detection and high-speed isolation of a faulty section of the busbar. To ensure the adaptability of the relay to any type of busbar configuration, the P747 is built with a universal topology processing algorithm. This algorithm determines the optimal tripping zone based on the current status of the plant isolators or/and circuit-breakers.

The P747 employs biased differential algorithms where the differential current is compared with a bias current. This characteristic ensures the stability of the protection for external faults, even with differing CT tolerance and errors which could lead to spurious operation. To increase the security of the differential protection, the biased differential element is supervised by a biased global check zone element. This ensures stability even under the erroneous status of the auxiliary contact of plant isolators and circuit-breakers.

The MiCOM Agile P747 also employs an innovative external fault detection algorithm - the current phase comparison. This ensures stability when CTs become saturated. This technique provides secure performance in heavy CT saturated conditions.

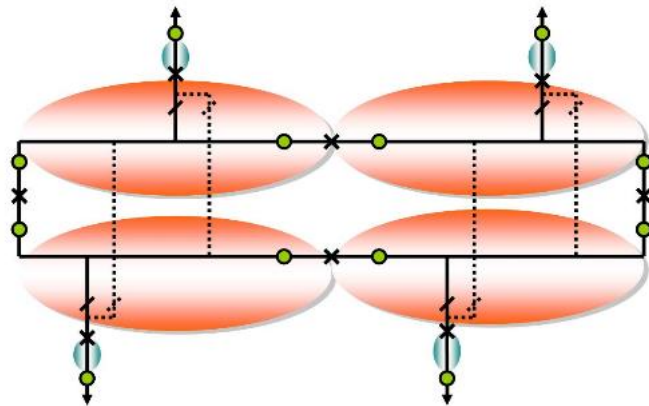

Universal online topology processing

MULTIPLE TRIPPING CRITERIA

The P747 maintains the highest levels of stability under all conditions, including hardware failure and incoherent signals applied from external equipment or generated by the power system. Any tripping order must therefore be made conditional to the simultaneous occurrence of at least five criteria:

Magnitude criteria

Confirmation of two simultaneous thresholds per zone:

- Exceeding the bias slope characteristic (k2)
- Exceeding differential operating current threshold ($I_D > 2$)

Check zone supervision

The zone element(s) are only permitted to trip if the order is confirmed by the check zone element:

- Exceeding the bias slope characteristic (kCZ)
- Exceeding differential operating current threshold ($I_D CZ > 2$)

Current phase comparison criteria

Current phase angle comparison (+/- 90 degree) between all phase currents above a settable threshold.

Optional voltage criteria

- Undervoltage $U <$

Bias differential characteristics

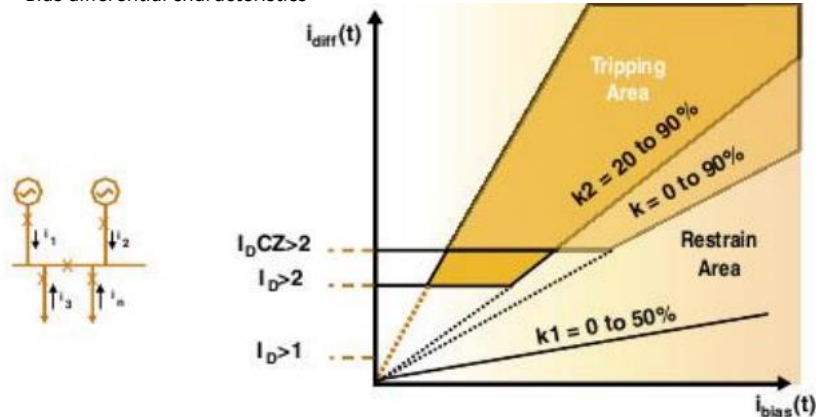

$$\text{Differential current: } i_{diff \text{ node}}(t) = i_1 + i_2 + i_3 + \dots + i_n$$

$$\text{Operating current: } i_{diff}(t) = |i_{diff \text{ node}}(t)| = |S \cdot i|$$

$$\text{Bias current: } i_{bias}(t) = |i_1| + |i_2| + |i_3| + \dots + |i_n| = S \cdot |i_n|$$

SYNCHRONOUS OR SEQUENTIAL TRIPPING

The MiCOM Agile P747 allows the delay of every or each tripping contact. This is highly recommended for high speed disconnection of the bar from the grid and delayed trip of the generation feeders.

DEAD ZONE OR BLIND SPOT PROTECTION

The current transformers or the open isolators surrounding the busbars define the limits of the main zones. When a feeder isolator is opened, a dead zone or blind spot is created to the associated CT. The P747 detects this condition automatically and provides protection for this zone. One stage of definite time delayed overcurrent protection is also provided.

CONTINUOUS SUPERVISION OF CURRENT CIRCUITS

The MiCOM Agile P747 detects any abnormality in the current circuit by continuously monitoring it.

Under normal operating conditions the differential current will be negligible. An anomaly is detected by a setting threshold ($I_b > 1$), which can be set to alarm from 10 A primary.

DIFFERENTIAL CURRENT SETTINGS

When switching operations are carried out in the substation, incorrect topology replicas may occur. In this case, a differential current appears. The differential elements of the MiCOM Agile P747 are allowed to operate only if the differential current reaches a threshold $I_b > 2$, which is normally set above the highest load current when no voltage criteria is used.

PHASE OVERCURRENT PROTECTION

Two independent stages of phase overcurrent protection are provided in the MiCOM Agile P747.

These elements provide additional protection for the individual circuits. The stages can be programmed as:

- First stage can be programmed as definite time (DT) delay or one of the nine inverse time (IDMT) curves (IEC/UK and IEEE/US)
- Second stage can only be programmed as definite time

CIRCUIT BREAKER FAILURE PROTECTION (LBB)

The MiCOM Agile P747 offers an in-built enhanced integrated solution for breaker failure protection.

In general, the breaker failure protection is executed on a per phase basis which involves the possibility of receiving tripping orders on a per pole basis. The P747 busbar protection can also work in co-ordination with external breaker failure protection relays. In this configuration, the receipt of an external breaker failure command results in the tripping of all the adjacent circuit-breakers, via the topological recognition system identifying which breaker is connected to which zone.

SECONDARY CURRENT TRANSFORMER RATIO CORRECTION

The MiCOM Agile P747 can correct a mix between current transformer ratios over a very wide range (up to 20). All protection elements work in primary values according to the settings of CT ratio per terminals. Its associated user interface provides a range between 1 A and 30 000 A primary. For displaying secondary differential current quantities, the P747 uses a settable virtual CT ratio irrespective of the feeder section concerned.

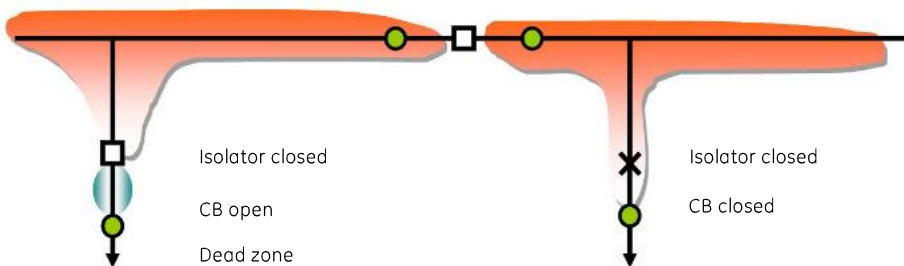

Dead zone protection

ISOLATION AND MAINTENANCE OPERATING MODE

For ease of operation or maintenance of the busbar protection system, the MiCOM Agile P747 can receive specific commands designed to allow system testing or other interventions without any danger of unwanted tripping.

In P747, a centralised command to isolate the busbars can be selectively applied per zone:

- Differential protection (87BB) and circuit-breaker failure protection (50BF) blocked
- The additional local protection functions (51, 27, etc...) remain operational

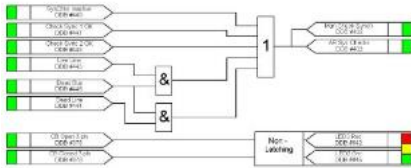

Programmable scheme logic editor S1 Agile

PROGRAMMABLE SCHEME LOGIC

Powerful programmable logic (PSL) allows the user to customise the protection and control functions. It is also used to program the functionality of the optically isolated inputs, relay outputs and tri-colour LED indications. The programmable logic comprises gate logic and general purpose timers. The gate logic includes OR, AND and MAJORITY gate functions, with the ability to invert the inputs and outputs and provide feedback.

The programmable logic is configured using the graphical MiCOM Agile interface.

PLANT STATUS

Checks and monitoring of the plant status can be made and an alarm raised for any discrepancy condition between the open and closed auxiliary contacts of the isolators and circuit-breakers.

REMOTE HMI

The real time remote HMI software allows the user to monitor the position of CBs and isolators in the busbar scheme, as well as currents, alarms, etc.

MEASUREMENT AND RECORDING FACILITIES

The MiCOM Agile P747 is capable of measuring and storing the values associated with a fault. All the events, fault records and disturbance records are time tagged to 1 ms using an internal real time clock. An optional IRIG-B port is also provided for accurate time synchronisation. A lithium battery provides a back up for the real time clock and all records in the event of supply failure

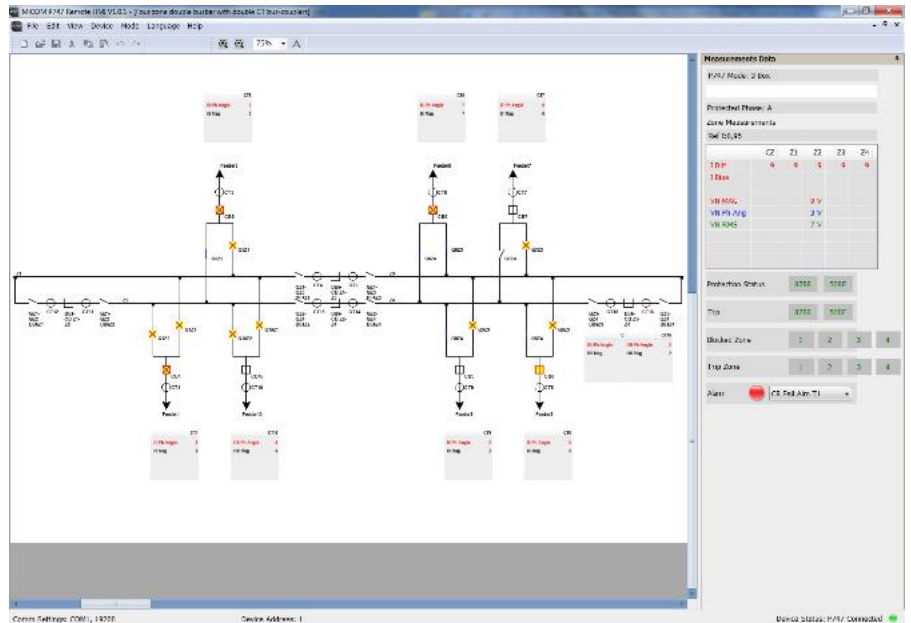

Remote HMI

MEASUREMENT

The measurements provided, which may be viewed as primary or secondary values, can be accessed via the backlit liquid crystal display. They are also accessible via the communications ports. The following instantaneous parameters can be viewed:

- Phase current magnitude IA and/or IB and/or IC
- Phase current angle IA and/or IB and/or IC
- Voltage magnitude and angle
- Frequency
- Differential current Idiff / phase / zone
- Bias current I_{bias} / phase / zone
- Check zone Idiff / phase
- Check zone I_{bias} / phase

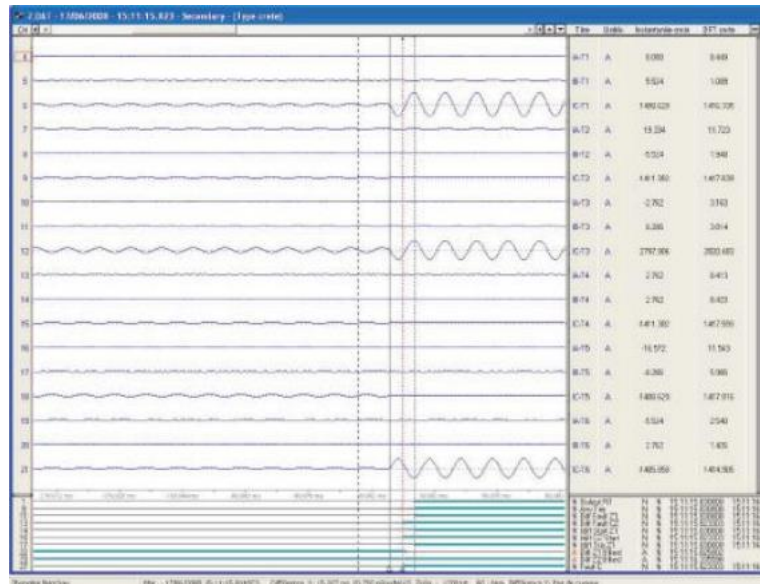

Disturbance record viewed in S1 Agile

EVENT RECORDER

Up to 512 time-tagged event records are stored in battery backed memory and can be extracted via the communications port or viewed on the front panel display.

FAULT RECORDER

Records of the last five faults are stored in the battery backed memory. Each fault record includes:

- Faulted phase
- Indication of the faulty zone
- Date and time
- Active setting group
- Fault duration
- Currents, frequency and voltage

DISTURBANCE RECORDER

The P747 has an independent disturbance recording facility. It can record 18 analogue and 32 digital channels in addition to 1 time channel.

Specific analogue channels:

- VA, VB and VC per zone
- Ix1 to Ix18 (x is A or B or C) in 3-box mode

Maximum duration of one record and number of records: up to 10.5 s per record and minimum of 50 records, 1.5 s (memory of 75 s).

Disturbance records can be extracted from the relay via the remote communications and saved in the COMTRADE format. These records may be examined using S1 or any other standard COMTRADE viewer.



Fast, sensitive and secure - P747 - the centralised solution for busbar protection

LOCAL AND REMOTE COMMUNICATIONS

Two communications ports are available as standard: a rear port providing remote communications and a front port providing local communications. As an option, an Ethernet board can be added in the MiCOM Agile P747 to use one of the following protocols:

- 61850-8.1
- Courier
- DNP 3.0

The front RS232 port is designed for use with the S1 Agile, which fully supports functions within the relay by providing the ability to: program the settings offline, configure the programmable scheme logic, extract and view event, disturbance and fault records, view the measurement information dynamically and perform control functions (using the Courier protocol).

The default remote communications protocol is Courier / RS485 or K-bus and can be converted to IEC 60870-5-103. An optional second rear Courier communications port is available, which may be configured as RS232, RS485 or K-Bus.

Optional Ethernet IEC 61850 is also available offering: high-speed data exchange, peer-to-peer communications, reporting, disturbance record extraction and time synchronisation.

Device track record

Low impedance biased differential busbar protection, MBCZ, launched in 1988 with over 7000 cubicles sold

Over 3000 modular P740 low impedance busbar protection schemes delivered since launch in 2002

Since the launch of the P746 in 2008, over 1300 systems have been delivered

DIAGNOSTICS

The automatic tests performed, including power-on diagnostics and continuous self-monitoring, ensure a high degree of reliability. The results of the self-test functions are stored in battery backed memory. Test features available via the user interface provide examination of input quantities and states of the digital inputs and relay outputs. A local monitor port provides digital outputs selected from a prescribed list of signals, including the status of protection elements.

QUALITY BUILT-IN (QBi)

Grid Solutions' QBi initiative has deployed a number of improvements to maximise field quality. Harsh environmental coating is applied to all circuit boards to shield them from moisture and atmospheric contamination. Transit packaging has been redesigned to ISTA standards and the third generation of CPU processing boosts not only performance, but also reliability.

HARDWARE

The MiCOM Agile P747 includes:

- A backlit liquid crystal display
- LEDs: 18 tri-colour
- Function keys
- Hotkeys
- RS232 (front port) & RS485 / K-bus (rear port)
- Optional Ethernet rear communications board or
- Optional second rear communications board
- Optional IRIG-B port
- Download/monitor port
- Battery (supervised)
- N/O and C/O watchdog contacts
- Supervised +48 V field voltage
- CT inputs 1 A and 5 A
- Universal opto inputs with programmable voltage threshold. The optically isolated inputs are independent and may be powered from the +48 V field voltage.

For more information please contact
GE Grid Solutions

Worldwide Contact Center

Web: www.GEGridSolutions.com/contact
Phone: +44 (0) 1785 250 070

www.GEGridSolutions.com

