

GE
Grid Solutions

Multilin™ G100

Substation Gateway



Instruction Manual

994-0155

Version 1.00 Revision 0



GE Information

Copyright Notice

©2021, General Electric Company. All rights reserved.

The information contained in this online publication is the exclusive property of General Electric Company, except as otherwise indicated. You may view, copy and print documents and graphics incorporated in this online publication (the "Documents") subject to the following: (1) the Documents may be used solely for personal, informational, non-commercial purposes; (2) the Documents may not be modified or altered in any way; and (3) General Electric Company withholds permission for making the Documents or any portion thereof accessible via the internet. Except as expressly provided herein, you may not use, copy, print, display, reproduce, publish, license, post, transmit or distribute the Documents in whole or in part without the prior written permission of General Electric Company.

The information contained in this online publication is proprietary and subject to change without notice. The software described in this online publication is supplied under license and may be used or copied only in accordance with the terms of such license.

Trademark Notices

GE, Multilin and  are trademarks and service marks of General Electric Company.

* Trademarks of General Electric Company.

IEC is a registered trademark of Commission Electrotechnique Internationale. IEEE is a registered trademark of the Institute of Electrical and Electronics Engineers, Inc. Internet Explorer, Microsoft, and Windows are registered trademarks of Microsoft Corporation. DisplayPort™ are trademarks owned by the Video Electronics Standards Association (VESA®) in the United States and other countries. Intel® and Intel® Celeron® are trademarks of Intel Corporation or its subsidiaries in the U.S. and/or other countries.

Other company or product names mentioned in this document may be trademarks or registered trademarks of their respective companies.



This printed manual is recyclable.

Please return for recycling where facilities exist.

Table of Contents

Copyright Notice	2
Trademark Notices	2
Figures	6
Tables	7
About this Document.....	8
Purpose.....	8
Intended Audience.....	8
Additional documentation.....	8
How to use this document	8
Safety words and definitions.....	9
Product Support	10
Access the GE Grid Solutions web site	10
Search GE Grid Solutions Technical Support Library.....	10
Contact GE Grid Solutions technical support	10
GE Grid Solutions address.....	11
Product returns.....	11
Chapter 1 - Introduction to G100.....	12
Safety precautions.....	12
Warning symbols.....	13
Informational symbols.....	13
Hardware overview	14
Top Panel	15
Bottom Panel.....	16
Front Panel	17
Order Code.....	18
Spares and Accessories	19
Chapter 2 - Unpacking and Inspection	20
Electro Static Discharge - ESD.....	20
Initial inspection	21
Unpacking	22
Chapter 3 - Installing the G100.....	23
Installation.....	23
Wall / Panel Mounting instructions	23
DIN Rail Mounting instructions.....	26

Installation of optional D.20 HDLC Card	27
Grounding.....	30
Power Supply	30
Power-On Self-Test (POST)	31
Super Capacitor and Real Time Clock (RTC)	31
Chapter 4 - Interfaces and Indicators.....	32
UEFI Settings	32
General Purpose IO (GPIO)	32
Binary Inputs (DI): 8	32
Binary Outputs (DO): 4.....	34
Analog DC Inputs (AI): 4.....	36
D.20 Link Connections	39
G100 D.20 HDLC PCIe card	40
Supplying power through the D.20 Link.....	41
D.20 Peripheral Types	42
Peripheral compatibility with the D.20 HDLC PCIe card.....	42
D.20 Connection topologies	44
Serial ports (RS232/485, RJ45, labelled 1-4).....	49
RS-485 Serial Connections	50
Default Serial Maintenance port (port 4, RS232).....	52
Ethernet ports.....	52
TP Ethernet ports and LED indications (labelled 1, 2)	53
SFP Ethernet ports (labelled 3, 4)	53
Time synchronization IRIG-B input (2 pin connector)	55
DP Display Port	56
USB ports	58
Internal Buzzer	58
Chapter 5 - Specifications	60
G100 Product Specifications	60
System	60
Communications	60
Electrical	61
G100 Environmental Specifications.....	61
Temperature and Humidity	61

Ingress Protection (IEC 60529)..... 61

Mechanical Specifications 62

 Weight 62

 Dimensions 62

Storage recommendations 63

 Storage conditions 63

Chapter 6 - Removing the G100 from Service..... 64

 Remove configuration data and sensitive information from the G100 64

 Removing configuration data on a PC 64

Appendix A – Standards & Compliance 65

 Compliance Standards 65

Appendix B – Warranty..... 67

 Warranty 67

Appendix C – Glossary of terms used in this document 68

Modification Record 70

Figures

Figure 1: G100 Top Panel.....	15
Figure 2: G100 Bottom Panel.....	16
Figure 3: G100 Front Panel	17
Figure 4: Single D.20 terminated, single link - Topology	45
Figure 5: Dual D.20 link terminated - Topology	46
Figure 6: Single D.20 link, redundant LAN - Topology	47
Figure 7: Redundant D.20 link, redundant LAN - Topology	48
Figure 8: Modular connector 8P8C (RJ45) pins	50
Figure 9: G100 connection using RS485 2-wire	51

Tables

Table 1: Warning symbols that may appear on the G100 and in this manual.....	13
Table 2: Informational symbols that appear on the G100 and in this manual.....	13
Table 3: G100 Order Code	18
Table 4: GPIO DI connector pin assignments.....	33
Table 5: GPIO DO connector pin assignments	35
Table 6: GPIO AI connector pin assignments	37
Table 7: GPIO AI Voltage / Current selection jumper	38
Table 8: D.20 Port A and B pin out and configuration options	41
Table 9: Default D.20 Relay settings	41
Table 10: D20A Analog Input Module Compatibility.....	43
Table 11: D20S Status Input Module Compatibility	43
Table 12: D20K Control Output Module Compatibility	43
Table 13: D20C Combination Input/Output Module Compatibility.....	44
Table 14: Repeater/Splitter Compatibility	44
Table 15: Single D.20 terminated, Single Link - Default settings	45
Table 16: Dual D.20 link terminated – Default settings	46
Table 17: Single D.20 link, redundant LAN - Default settings	47
Table 18: Redundant D.20 link, redundant LAN - Default settings.....	48
Table 19: RJ45 Pin outs for Serial Port Signals	50
Table 20: SFP modules supported by the G100.....	54
Table 21: Ethernet cables required by the G100.....	55
Table 22: IRIG-B input connector pin assignments	55
Table 23: IRIG-B input signal selection TTL/RS-232	56

About this Document

Purpose

This manual provides information about installing, setting up, using and maintaining your G100 Substation Gateway. This manual does not provide any procedures for configuring the G100 software.

Intended Audience

This manual is intended for use by field technicians and maintenance personnel who are responsible for the installation, wiring and maintenance of SCADA equipment. This guide assumes that the user is experienced in:

- Electrical utility applications
- Electrical wiring and safety procedures
- Related other manufacturers' products, such as protective relays and communications equipment

Additional documentation

For further information about the G100, refer to the following documents.

- G100 Substation Gateway Quick Start Guide (SWM0116)
- MCP Software Configuration Guide (SWM0101)
- Configuring UEFI Settings on G100 User Guide (SWM0122)
- Module layouts, as available.
- G100 Online Help

How to use this document

This document describes how to install the G100.

Procedures are provided for all component options available for the G100. The components included in your G100 depend on what was ordered for your substation application. Follow only the procedures that apply to your G100 model.

To check what options are included in your G100, see *Order Code*.

Safety words and definitions

Before attempting to install or use the device, review all safety indicators in this document to help prevent injury, equipment damage or downtime.

The following safety and equipment symbols are used in this document:



Indicates a hazardous situation which, if not avoided, will result in death or serious injury.



Indicates a hazardous situation which, if not avoided, could result in death or serious injury.



Indicates a hazardous situation which, if not avoided, could result in minor or moderate injury.



Indicates practices that are not related to personal injury.



Important information about the product, product handling which must be given attention.

Product Support

If you need help with any aspect of your G100 product, you can:

- Access the G100 Web site
- Search the GE Technical Support library
- Contact Technical Support

Also covered are:

- The GE Grid Solutions address
- Instructions on returning a G100

Access the GE Grid Solutions web site

The G100 Web site provides fast access to technical information, such as manuals, release notes and knowledge base topics.

Visit us on the Web at: <http://www.gegridsolutions.com>

Search GE Grid Solutions Technical Support Library

This site serves as a document repository for post-sales requests. To get access to the Technical Support Web site, go to:

Visit us on the Web at: http://sc.ge.com/*SASTechSupport

Contact GE Grid Solutions technical support

GE Grid Solutions Technical Support is open 24 hours a day, seven days a week for you to talk directly to a GE representative.

In the U.S. and Canada, call toll-free: 1 800-547-8629

International customers, please call: + 1 905-927-7070

Or e-mail to G100 Local region contact support:

- ga.supportNAM@ge.com - North America
- ga.supportLAM@ge.com - Latin America
- ga.supportCEAP@ge.com - China, East Asia, Pacific
- ga.supportERCIS@ge.com - Europe, Russia, Commonwealth of Independent States
- ga.supportIND@ge.com - India

- ga.supportMENAT@ge.com - Middle East, North Africa, Turkey

Have the following information ready to give to Technical Support:

- Ship to address (the address that the product is to be returned to)
- Bill to address (the address that the invoice is to be sent to)
- Contact name
- Contact phone number
- Contact fax number
- Contact e-mail address
- Product number / serial number
- Description of problem

Technical Support will provide you with a case number for your reference.

GE Grid Solutions address

The GE Grid Solutions company address is:

GE Grid Solutions
650 Markland Street
Markham, Ontario
Canada L6C 0M1

Product returns

A Return Merchandise Authorization (RMA) number must accompany all equipment being returned for repair, servicing, or for any other reason. Before you return a product, please contact GE's Grid Solutions to obtain an RMA number and instructions for return shipments.

You are sent the RMA number and RMA documents via fax or e-mail. Once you receive the RMA documents, attach them to the outside of the shipping package and ship to GE.



Product returns are not accepted unless accompanied by the Return Merchandise Authorization number.

Chapter 1 - Introduction to G100

Before you begin installing and using the G100, review the information in this chapter, including the following topics:

- Safety precautions
- Warning symbols
- Informational symbols
- Hardware overview
- Order Code
- Spares and Accessories

Read and thoroughly understand this guide before installing and operating the unit. Save these instructions for later use and reference.



Failure to observe the instructions in this manual may result in serious injury or death.

Safety precautions

Follow all safety precautions and instructions in this manual.







Only qualified personnel should work on the G100. Maintenance personnel should be familiar with the technology and the hazards associated with electrical equipment.

- *Never* work alone.
- Before performing visual inspections, tests, or maintenance on this equipment, isolate or disconnect all hazardous live circuits and sources of electric power. Assume that all circuits are live until they have been completely de-energized, tested, and tagged. Pay particular attention to the design of the power system. Consider all sources of power, including the possibility of back feed.
- Turn off all power supplying the equipment in which the G100 is to be installed before installing and wiring the G100.
- Operate only from the power source specified on the installed power supply module.
- Beware of potential hazards and wear appropriate personal protective equipment, safety shoes, eye protection and gloves.
- The successful operation of this equipment depends upon proper handling, installation, and operation. Neglecting fundamental installation requirements may lead to personal injury as well as damage to electrical equipment or other property.
- All electronic components within the G100 are susceptible to damage from electrostatic discharge. To prevent damage when handling this product use approved static control procedures.
- Hazardous voltages can cause shock, burns or death. To prevent exposure to hazardous voltages, disconnect and lock out all power sources before servicing and removing components.
- If the G100 is used in a manner not specified in this manual, the protection provided by the equipment may be impaired.
- Changes or modifications made to the unit not authorized by GE could void the warranty.

Warning symbols

Table 1 explains the meaning of warning symbols that may appear on the G100 or in this manual.



Table 1: Warning symbols that may appear on the G100 and in this manual







Symbol	Description
	The relevant circuit is direct current.
	The relevant circuit is alternating current.
	Caution: Refer to the documentation for important operation and maintenance instructions. Failure to take or avoid specified actions could result in loss of data or physical damage.
	Warning: Dangerous voltage constituting risk of electric shock is present within the unit. Failure to take or avoid specified actions could result in physical harm to the user.
	Earth/Ground Terminal
	Protective Ground Terminal
	Caution: Hot Surface

Informational symbols

Table 1 explains the meaning of informational symbols that may appear on the G100 or in this manual.

Table 2: Informational symbols that appear on the G100 and in this manual

Symbol	Description
	Power On
	CPU Status
	Ethernet Port

	Serial Port
	IRIG-B Time In
	Display Port
	Analog DC Input (AI)
	Binary Input (DI)
	Binary Output (DO)

Hardware overview

MCP is the Multifunction Controller Platform family of Substation Gateways by GE Grid Solutions.

G100 is the smaller member of the family, together with G500.

G100 is based on Intel® Apollo Lake SOC, with Intel Atom X5-E3930 1.3GHz Processor to provide quality performance with low power consumption and wide operating temperature. It has 8 Gigabytes of SoDIMM 204 pin DDR3L memory.

The G100 is distinguished by the noticeable lack of a hard drive and fan, employing instead the rugged and reliable Solid State Drive (SSD) mass storage and engineered heat sink.

The G100 supports various communication media types through a choice of input/output (I/O):

- Serial: 4 factory installed ports, RS-232 and RS-485 configurable, accessible via individual RJ45 connectors.
- Ethernet: 2 factory installed RJ45 Ethernet interfaces with to 2 additional SFP cages..
- D.20 Link HDLC ports: A dual channel PCIe card for communication with up to 60 – D.20 Peripherals channel, including redundant D.20 link configuration.
- IRIG-B TTL input
- Local General Purpose IO (GPIO) interface, providing:
 - 8 Binary Inputs (DI), wetted internally from main unit power supply circuit using single common (positive voltage through external contacts). The binary inputs are individually isolated internally.
 - 4 Binary Outputs (DO), isolated, as N.O. (Normal Open) single contact
 - 4 DC Analog Input (AI) channels, +5V DC/ 20mA

The G100 device has 3 noticeable side panels for operation.



The names of each side panel as referenced in this document assume a G100 being positioned vertically.

Top Panel

The top panel of the G100 provides access to:

1. 1x DP display port
2. 2x TP Ethernet ports with LED indications (labelled 1, 2)
3. 2x SFP Ethernet ports (labelled 3, 4)
4. 2x USB2 ports
5. 1x USB3 port
6. 1x USB-C port (future, currently not used)
7. 4x Analog Input (AI) connections (12 pin connector)
8. 4x Binary Output (DO) connections (8 pin connector)
9. D.20 HDLC connections, with LED indications (optional, in PCIe slot)

Figure 1: G100 Top Panel

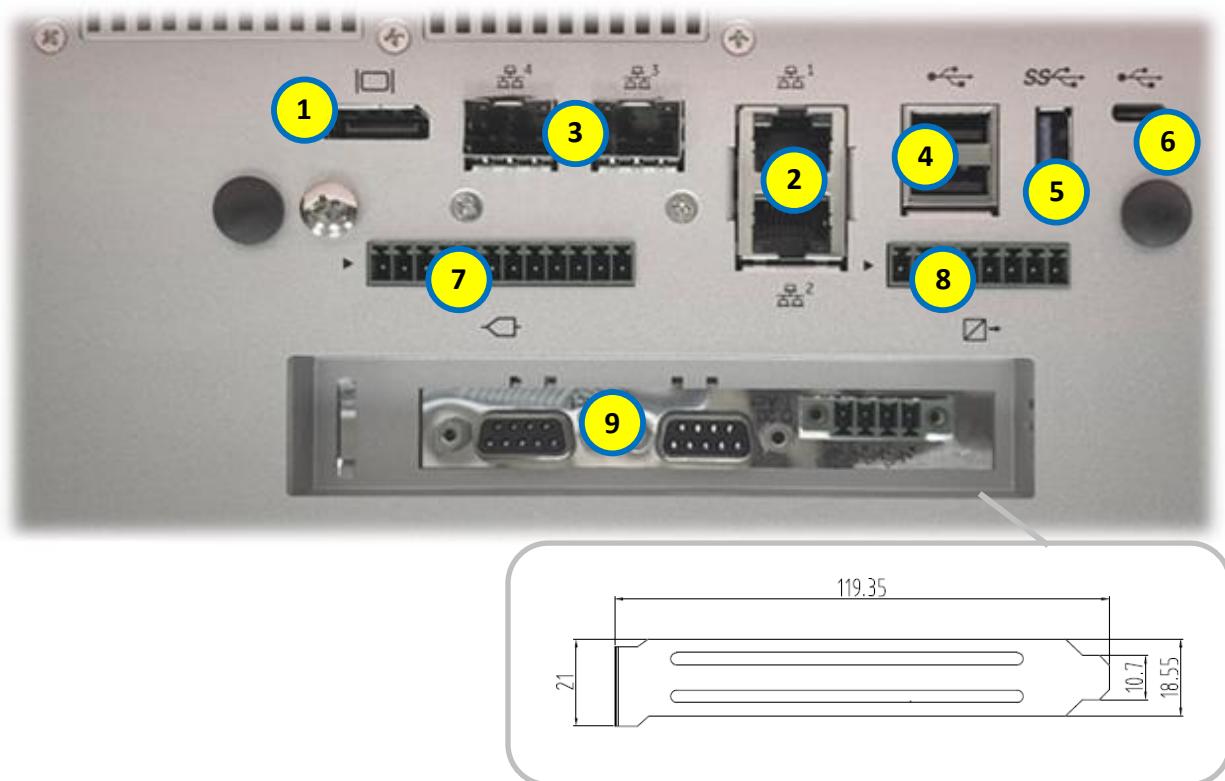

Bottom Panel

The bottom panel of the G100 provides access to:

10. 4x Serial ports (RS232/485, RJ45, labelled 1-4)
11. 8x Binary Input (DI) connections (16 pin connector)
12. Time synchronization input with IRIG-B TTL input (2 pin connector)
13. Power Supply connection (2 pin connector)
14. Protective Earth (PE) Ground connection (screw)

Figure 2: G100 Bottom Panel

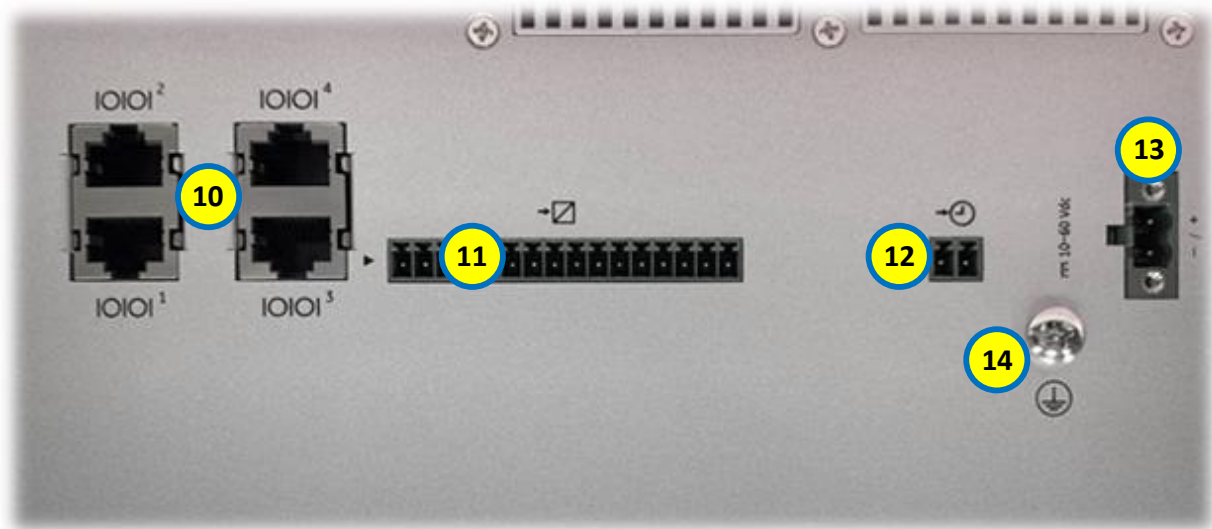

Front Panel

The front panel of the G100 provides the following LED indications:

15. 8x LED for Binary Input (DI)
16. 4x LED for Binary Output (DO)
17. LED for Analog Input (AI) sampling indication
18. SFP Ethernet (3, 4) link status LED
19. 4x Serial ports status LED
20. IRIG-B Input status LED
21. Power On LED
22. CPU/HW status LED, is ON when the unit operates normally

Figure 3: G100 Front Panel

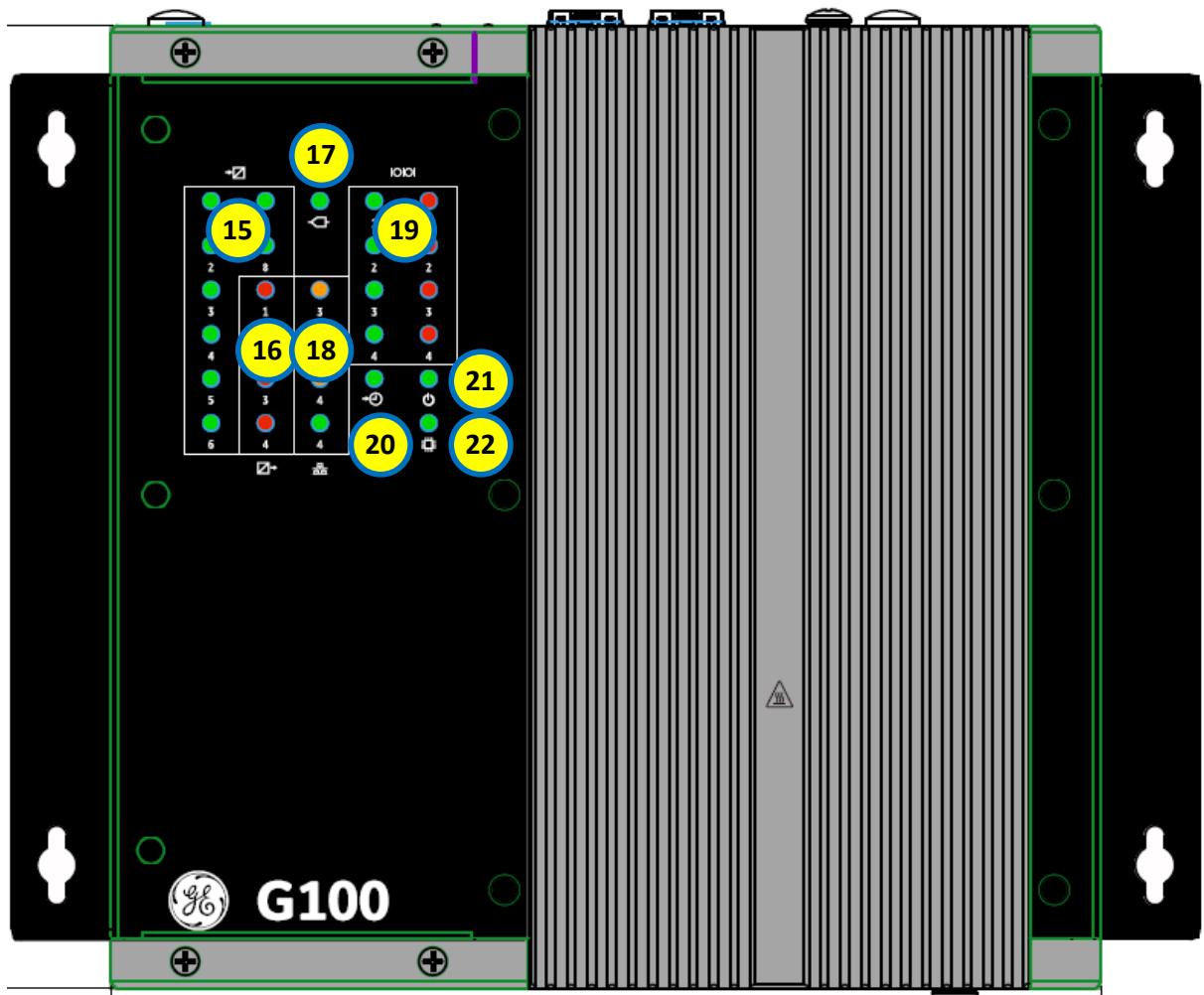

Order Code

Table 3: G100 Order Code

Order Code Item	Hardware configuration										Software configuration			Description										
	G100	A	A	L	-	D	A	-	4	T	T	*	*		-	*	U	U	-	**	**	-	UU	
CPU and Memory	A																							1.3GHz 2-core CPU, 8GB RAM
Storage		A																						16GB Solid State Drive
Power Supply				L																				12-54VDC (10.8-59.4 absolute min/max)
Digital Input / Output						D																		8x DI 12/24/48Vdc, 5mA & 4x DO 60Vdc (max.), 1A
DC Analog Inputs							A																	4x ±5Vdc/ 20mA analog input
Serial Ports								4																4x Serial Ports, RS-232/ RS-485 independently configurable and isolated
Ethernet Interface - Built In									4	T	T													10/100/1000BASE-TX (RJ45 copper)
Ethernet Interface - SFP type												C	C											100BASE-TX (RJ45 copper) [0123-0004]
												T	T											1000BASE-TX (RJ45 copper) [580-3786]
												F	F											100BASE-FX (LC fiber multimode) [580-3784]
												S	S											1000BASE-SX (LC fiber multimode) [580-3785]
												L	L											1000BASE-LX (LC fiber single-mode) [580-3787]
												U	U											Not Required
PCIe Expansion Module																D								2x D.20 Link Ports [528-1007LF]
																U								Not Required
Firmware Version																			00					Latest Firmware Version (Default)
																			B2					v2.2 firmware version
Licenses																					xxx			SW Licenses (ARRM, IEC61850-Client, LogicLinx IEC 61131-3)

To know the Order Code of your G100, run **mcpsi** command through the Shell access utility (see Quick Start Guide and Software Manual for more details).

“As-Built” is the order code at factory build time.

“As-Is” is the order code at the time when the user runs the command.

In the example below, after the unit was built in the factory, there were added and configured two Fiber Optic SFP (F) and a D.20 PCIe card (D).

```

admin@G100:~$ mcpsi
Retrieving the GE Multilin MCP system information, please wait ...

=====
                        GE Multilin MCP System Information
=====

Model Number:
    As-Built:      G100-AAL-DA-4TTUU-UUU-B2022-UU
    As-Is   :      G100-AAL-DA-4TTFF-DUU-B2022-UU
    
```

Please visit the online store for application licenses ordering codes. For latest configuration and options, please visit the online store and search for G100:

<https://store.gegridsolutions.com/Home.aspx>

Spares and Accessories

	MCP-S	-	*	-	*	Description	
Spare type							
			1			SFP Transceiver	
			3			PCIe Card	
SFP Transceiver options							
					F	SFP Module 100BASE-FX LC TRANSCEIVER OPTICAL MULTI-MODE 1300nm -40 TO 85C [580-3784]	These options are only available when Spare type is SFP Transceiver
					S	SFP Module 1000BASE-SX LC TRANSCEIVER OPTICAL MULTI-MODE 850nm -40 TO 85C [580-3785]	
					T	SFP Module 1000BASE-TX RJ45 TRANSCEIVER COPPER -40 TO 85C W/WO RX_LOS [580-3786]	
					L	SFP Module 1000BASE-LX LC TRANSCEIVER OPTICAL SINGLE-MODE 1310nm -40 TO 85C (580-3787)	
					C	SFP Module 10/100BASE-TX RJ45 TRANSCEIVER COPPER -40 TO 85C W/WO RX_LOS [0123-0004] (G100 Only)	
D.20 Card options							
					E	G100 PCIe D.20 HDLC CARD, 2x D.20 Link Ports (528-1007LF)	This option is only available when Spare type is PCIe Card

Chapter 2 - Unpacking and Inspection

This chapter covers the suggested inspection and preparation considerations and background information necessary prior to using the G100.

Unpacking, initial inspection, and first time operation of the G100 are covered.

Following the procedures given in the chapter is recommended, and they will verify proper operation before the product is integrated into your system.



Hot Surface: During operation of the G100 the surface of the heat sink, can reach a temperature of 60°C and above. Therefore, be careful and do not touch it with bare fingers.

Electro Static Discharge - ESD

The discharge of static electricity, known as Electro Static Discharge or ESD, is a major cause of electronic component failure. The Industrial Computer has been packed in a static-safe bag which protects it from ESD while it is in the bag. Before removing the Boards or any other electronic product from its static-safe bag, be prepared to handle it in a static-safe environment.



You should wear a properly-functioning anti-static strap and ensure you are fully grounded. Any surface upon which you place on the unprotected G100 should be static- safe, usually facilitated by the use of anti-static mats. From the time the board is removed from the anti-static bag until it is in the card cage and functioning properly, extreme care should be taken to avoid “zapping” the board with ESD. You should be aware that you could “zap” the board without you knowing it; a small discharge, imperceptible to the eye and touch, can often be enough to damage electronic components. Extra caution should be taken in cold and dry weather when electrostatic charge easily builds up.

Only after ensuring that both you and the surrounding area are protected from ESD, carefully remove the board or module from the shipping carton by grasping the module on its edges. Place the board, in its anti-static bag, flat down on a suitable surface. You may then remove the board from the anti-static bag by tearing the ESD warning labels.

Initial inspection

After unpacking the products, you should inspect it for visible damage that could have occurred during shipping or unpacking. If damage is observed (usually in the form of bent component leads or loose socketed components), contact GE Technical Support for additional instructions. Depending on the severity of the damage, it may be necessary to return the product to the factory for repair.

⚠WARNING

DO NOT apply power to the product if it has visible damage!

Doing so may cause further, possibly irreparable damage, as well as introduce a fire or shock hazard.

The G100 shipment will include the following:

- G100 Substation Gateway
- Wall / Panel mounting kit
 - Wall / panel mounting bracket (quantity 2)
- DIN rail and Hardware kit
 - DIN Rail (quantity 1)
 - Screws (quantity 6)
- Analog DC Input (AI) connector (quantity 1)
- Binary Input (DI) connector (quantity 1)
- Binary Output (DO) connector (quantity 1)
- Power input connector (quantity 1)
- IRIG-B input connector (quantity 1)



Unpacking

Please read the manual carefully before unpacking the board or module or fitting the device into your system. Also adhere to the following:

- Observe all precautions for electrostatic sensitive modules
- Do not place the board on conductive surfaces, anti-static plastic, or sponge, which can cause shocks and lead to board trace damage.
- Do not exceed the specified operational temperatures.
- Keep all original packaging material for future storage or warranty shipments of the board.

Although the products are carefully packaged to protect against the rigors of shipping, it is still possible that shipping damage can occur. Careful inspection of the shipping carton should reveal some information about how the package was handled by the shipping service. If evidence of damage or rough handling is found, you should notify the shipping service and GE Technical Support as soon as possible.



NOTE

PCIe Cards and storage devices may also have temperature restrictions

Retain all packing material in case of future need.

WARNING

Before installing or removing any board, please ensure that the system power and external supplies have been turned off!

Chapter 3 - Installing the G100

This chapter covers the installation of the G100 and initial power-on operations.

⚠ WARNING

Before you install and operate the G100, read and follow the safety guidelines and instructions in *Safety precautions*.

Installation

The G100 device can be installed as either wall / panel mounted, or DIN Rail mounted.

The G100 shall be installed in:

- Pollution Degree II, non-hazardous and restricted access location,
- Environment where the ambient temperature does not exceed the rating of the product,
- Air flow is not restricted

Wall / Panel Mounting instructions

Please see following instructions to mount it.

1. Mount the wall/panel mount bracket as shown below.
 - a. Locate and retrieve the wall/panel mount brackets from the G100 carton.
 - b. Locate and removed the 2x M3 screws on the left side of the chassis closest to the rear.
 - c. Position one of the wall/panel mount brackets to the chassis, aligning the mounting holes in the bracket to the chassis.
 - d. Reinstall the 2 screws removed in the step above on the left side of the chassis to secure the bracket to the chassis. The recommended torque setting for the M3 screws are 5.2 in-lb [0.59 Nm].
 - e. Repeat the above steps for the mounting the bracket to the right side of the chassis.

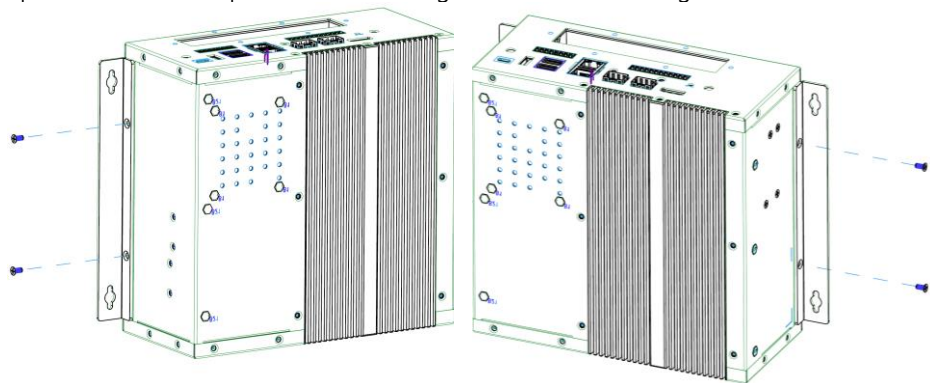

2. On the wall / panel, measure the exact place where you want to install the G100 and drill four holes that match the four mounting holes on both brackets.

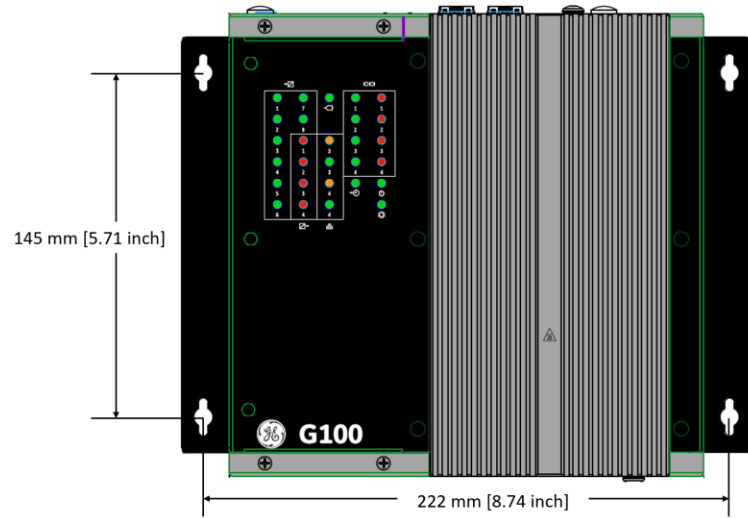

3. Insert four anchoring bolts into the holes, or suitable panel nuts that match your mounting screws.

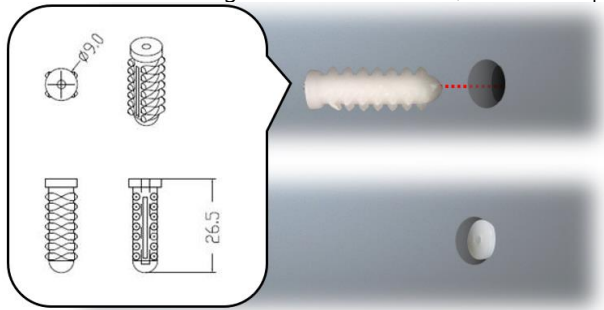

4. Align the G100 brackets with the four bolts / nuts you just installed on the wall / panel.

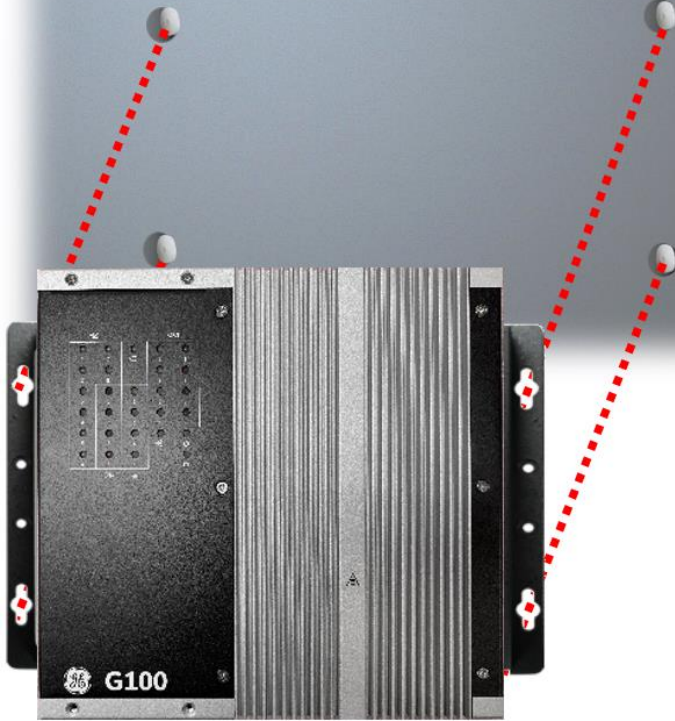

5. Drive the mounting screws into the anchoring bolts / nuts to secure the G100.

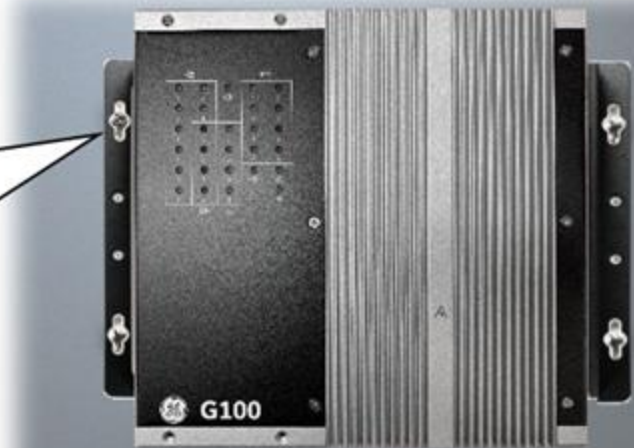
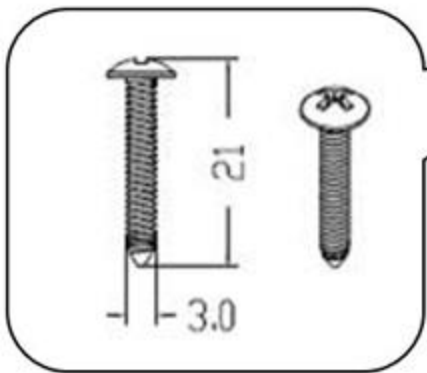

DIN Rail Mounting instructions

Please see following instructions to mount it.

1. Mount the DIN rail as shown below.
 - a. Locate and retrieve the DIN rail bracket and mounting screws from the G100 carton.
 - b. Position the DIN rail bracket to the rear of the chassis, aligning the mounting holes in the rail to the chassis.
 - c. Install the 6 screws provided with the DIN rail bracket to secure the bracket to the chassis. The recommended torque setting for the 6/32 screws are 5.2 in-lb [0.59 Nm].



The top of the DIN rail bracket should be positioned to align with the top of the G100 chassis.

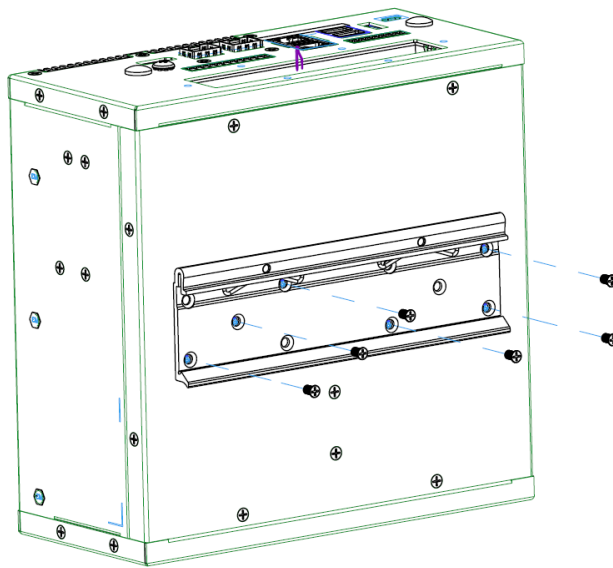

2. Position the G100 on a slight angle and slowly lower until the top of the DIN bracket on the G100 engages the DIN rail. Pull the G100 firmly downward and press flat against the wall/panel until the DIN rail bracket locks into position.

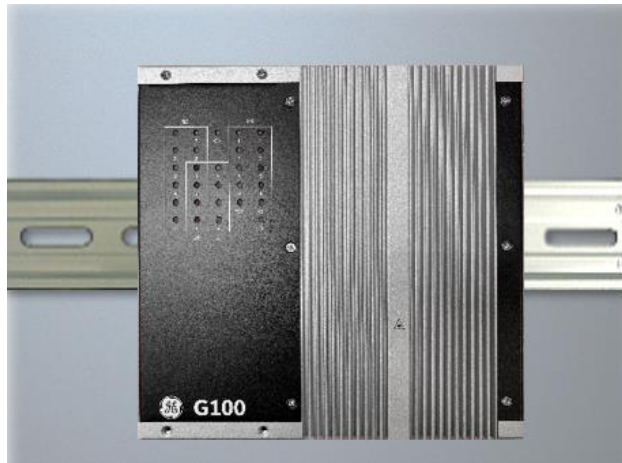

1.

Installation of optional D.20 HDLC Card

The optional D.20 HDLC card can be ordered already installed with the unit at factory time, or can be installed later, as follows.

NOTICE

Before you open the G100 chassis to install the D.20 HDLC Card, read and follow the guidelines and instructions in [Electro Static Discharge - ESD](#)

1. To install the D.20 HDLC card, flip over the system and loosen and remove the eight screws indicated below so that the chassis cover can be removed.



2. Place the card into the system as shown in the picture.

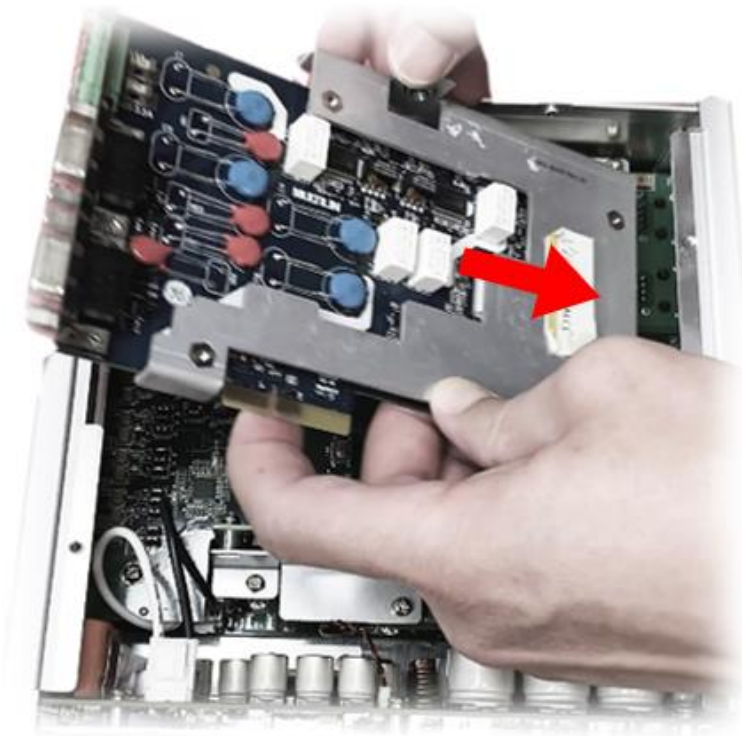

3. Align the notch of the module with the socket key in the slot and carefully insert the card into the slot.



4. Make sure the card slot has complete insert to these 2 metal sheets.

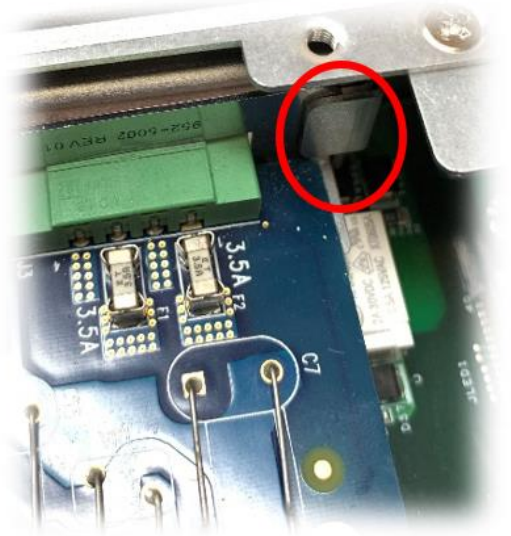
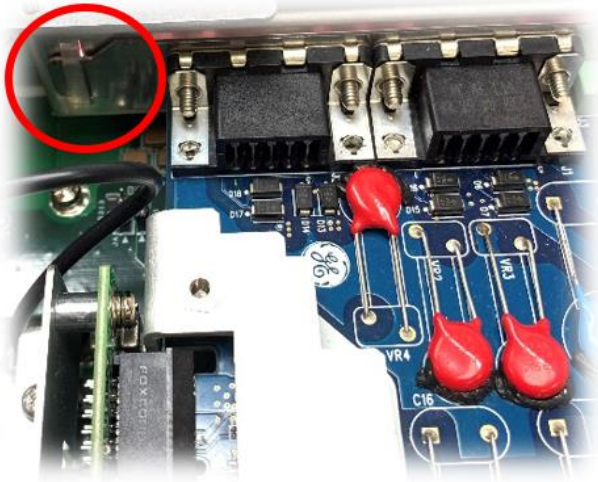

5. Connect the metal sheets with the system by securing the two screws.

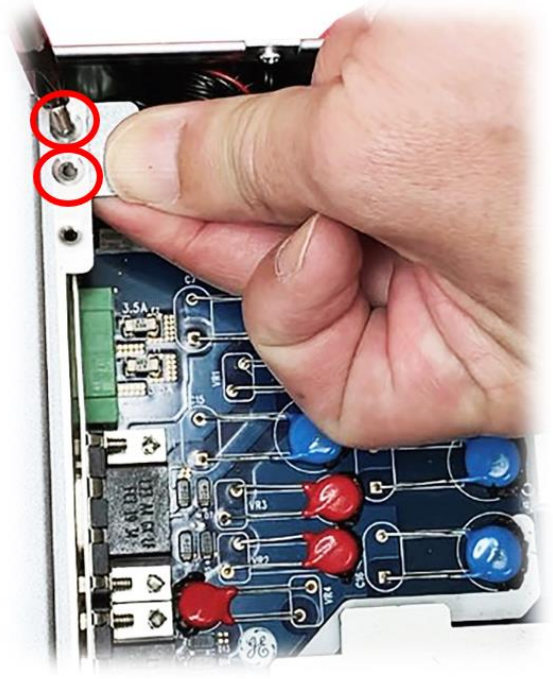

6. Place the cover back to the system and secure it with eight screws.

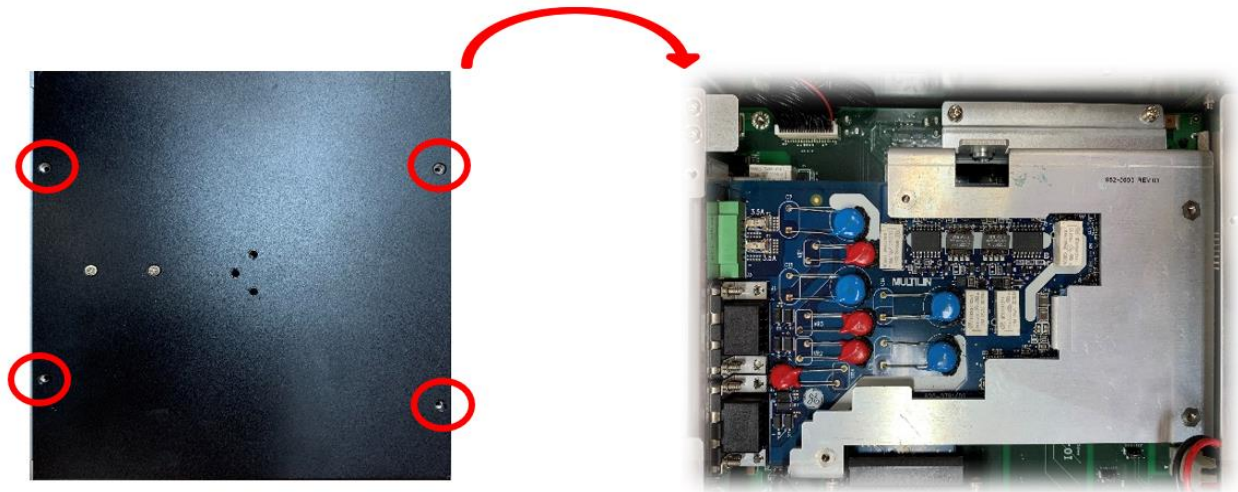

Grounding

It is required to connect the G100 chassis to cabinet ground, which then **MUST BE CONNECTED TO** Building Protective Earth (PE) ground using the ground connection screw located near the G100 power supply connector on the bottom side panel.

⚠ WARNING An improperly wired ground connection could place hazardous voltages on accessible metal parts.



Power Supply

The G100 is intended to be powered by a UL list DC power supply or DC power source, via one 2 Pin DC-IN connector located on the bottom side panel.

The power input is rated 12/24/48Vdc, 5/2.5/1.25A minimum, Tmax = 70 degree C, and the altitude of operation = 5000m.

Power supply range is 10 - 60VDC.

The device has a maximum power consumption of 60 W.

Make sure you connect the "+" and "-" wires according to the label adjacent to the connector.

Wires	The conductor size is from 16 AWG to 12 AWG and Strip Length is 7mm. After plugging cable lines into the mating connector, plug the mating connector to the product and secure the plug with the two screws.
Breaker circuit	A 20A IEC/USA/Canada breaker circuit is required as pre fuse.
Disconnect device	A readily accessible disconnect device shall be incorporated external to the unit.
Inrush current	The inrush current is typically 8A when powering up.
Reverse polarity protection	The product is equipped with built-in reverse polarity protection. If + and - are swapped the unit will not power-up and harm to neither the power supply nor the unit will occur.
Overcurrent protection	The overcurrent protection function interrupts an uncontrolled fault current or overcurrent before serious damage can occur, such as overheating of the equipment. The internal fuse is rated for 10A continuous current. If that current is exceeded by factor 10 the fuse will blow in between 1ms and 10ms. The fuse is placed in "+" connection of the power supply.

Power-On Self-Test (POST)

Each time the G100 boots up it must pass the POST (Power-On Self-Test).

If the G100 does not pass POST, the board will fail the POST and "beep" in a specific pattern. Please contact GE's Grid Solution support in this case.



NOTE

Full completion of the POST and applications available to run may take up to 3 minutes.

NOTICE UEFI and POST messages are displayed on the Video output (DP) port, and **if enabled** on the maintenance serial port. Refer to section "Default Serial Maintenance port (port 4, RS232)" on page 52 for additional information on the serial maintenance port.

Super Capacitor and Real Time Clock (RTC)

The G100 does not include a battery. Instead, the G100 contains one super capacitor, powering the real-time clock (RTC). This super capacitor will power the RTC for at least 5 days with no connection to power.

After this super capacitor discharges, UEFI settings will default to their factory default values (see section *UEFI Settings*) and the **RTC** time will be reset **internally** to an invalid time (e.g. 12:00 AM, 01-10-2000), and will be later updated to the correct time after the system will be powered on again and time synchronized again.

When the system is subsequently powered up, the system time will be initialized to the RTC time if the super capacitor was not discharged. If the super capacitor was discharged, the system time will be initialized to the last time when the system was still powered on.

Chapter 4 - Interfaces and Indicators

This chapter covers the interfaces of the G100 Substation Gateway.

UEFI Settings

Please refer to the document *Configuring UEFI Settings on G100 User Guide (SWM0122)* for details.

G100 device has the following UEFI settings that will revert to default values after the internal super capacitor has been discharged due to the device being powered off for extended time (typically more than 5 days).

These UEFI settings are applicable only while the G100 is starting.

After the applications started, these settings are over-written by the values configured in *MCP Local Configuration Utility (mcpcfg)* or *MCP Settings GUI* (which are persistent).

- Default Serial Maintenance Port used as UEFI (boot) console when KVM is not available (Advanced->Serial Port Console Redirection)
 - Console Redirection is set to Disabled for COM1-COM3, please do not change these settings.
 - Console Redirection for COM4 should be enabled/disabled and have the "Bits per second", to be same as in *the Serial Maintenance Port in MCP Studio* (See *MCP Software Configuration Guide SWM0101 > Serial Maintenance Port*).
- Default Serial Ports Modes (Advanced->Super IO Configuration)
 - Please ensure are enabled/disabled as required for secure hardening purposes and set to RS-232.

Users should check again these UEFI settings when the G100 is powered on again, and adjust as necessary.

General Purpose IO (GPIO)

G100 is equipped with an internal General Purpose Input/Output (GPIO) interface.

The available GPIO signal types are as follows.

Binary Inputs (DI): 8

All DI are wetted internally from main power supply circuit using single common for all 8 channels.

Each DI channel can be triggered by N.O. potential free external contacts, with the wetted positive voltage being switched through the external contacts.



NOTE

The DI wetting voltage is protected internally by the main fuse.

The DI voltage supply is the same as the G100 Power Supply: 12/24/48 VDC, with each DI channel consuming typically 5mA.

DI wiring is via a pluggable connector, pitch 3.5mm x 16 pins, located on the bottom side panel:

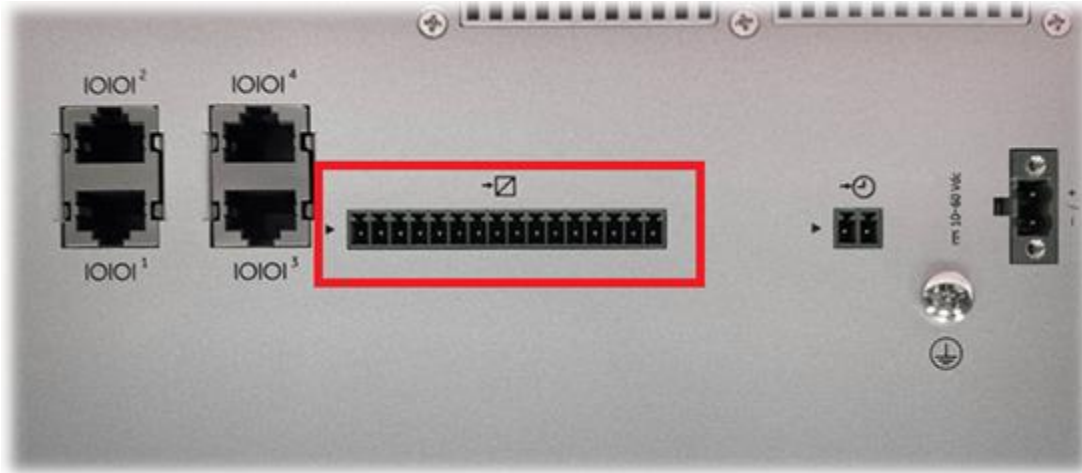

The small arrow on the left indicates PIN 1.

Table 4: GPIO DI connector pin assignments

PIN NO.	DESCRIPTION
1 (arrow)	DI_1
2	DI_COM (+)
3	DI_2
4	DI_COM (+)
5	DI_3
6	DI_COM (+)
7	DI_4
8	DI_COM (+)
9	DI_5
10	DI_COM (+)
11	DI_6
12	DI_COM (+)
13	DI_7
14	DI_COM (+)
15	DI_8
16	DI_COM (+)

Each DI channel is indicated as “input active” (ON) at runtime via a numbered LED located on the front side of the G100:

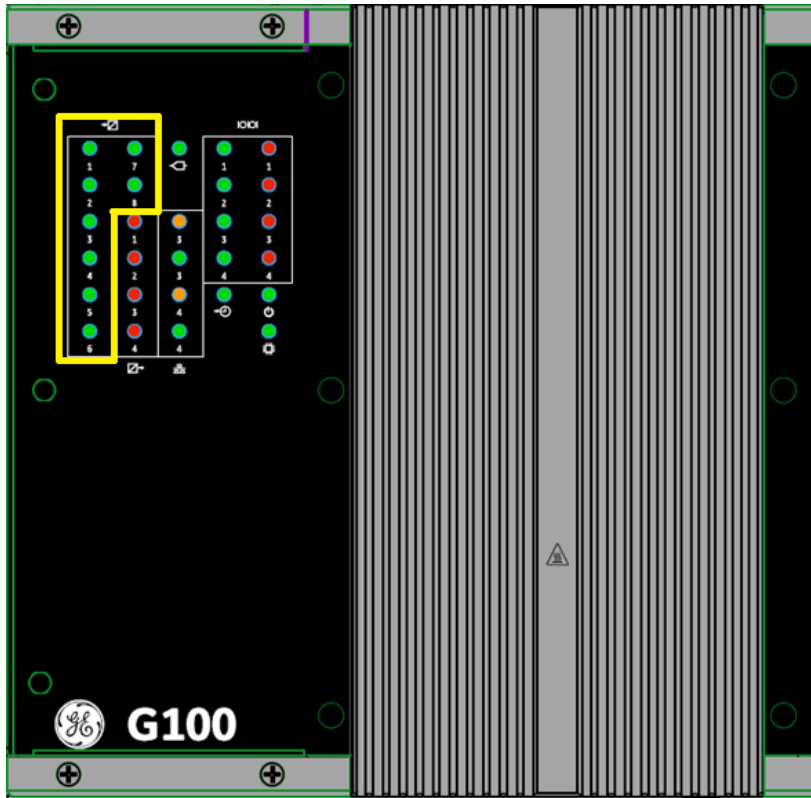

Binary Outputs (DO): 4

Each DO channel is isolated and independent, and provides a N.O. (Normal Open) dry relay single contact, rated at 10 – 60 VDC / 1A (Max.).



The DO channels are not fused internally.

NOTE

DO wiring is via a pluggable connector, pitch 3.5mm x 8 pins, located on the top side panel:

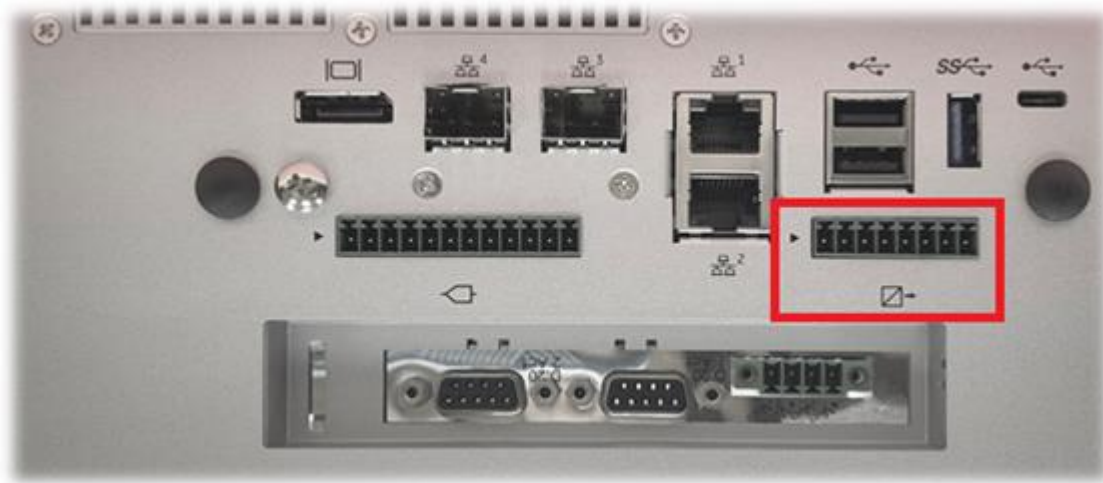

The small arrow on the left indicates PIN 1.

Table 5: GPIO DO connector pin assignments

PIN NO.	DESCRIPTION
1 (arrow)	RELAY1_NO1
2	RELAY1_COM1
3	RELAY2_NO1
4	RELAY2_COM1
5	RELAY3_NO1
6	RELAY3_COM1
7	RELAY4_NO1
8	RELAY4_COM1

Each DO channel is indicated as “active” (ON) at runtime via a numbered LED located on the front side of the G100:

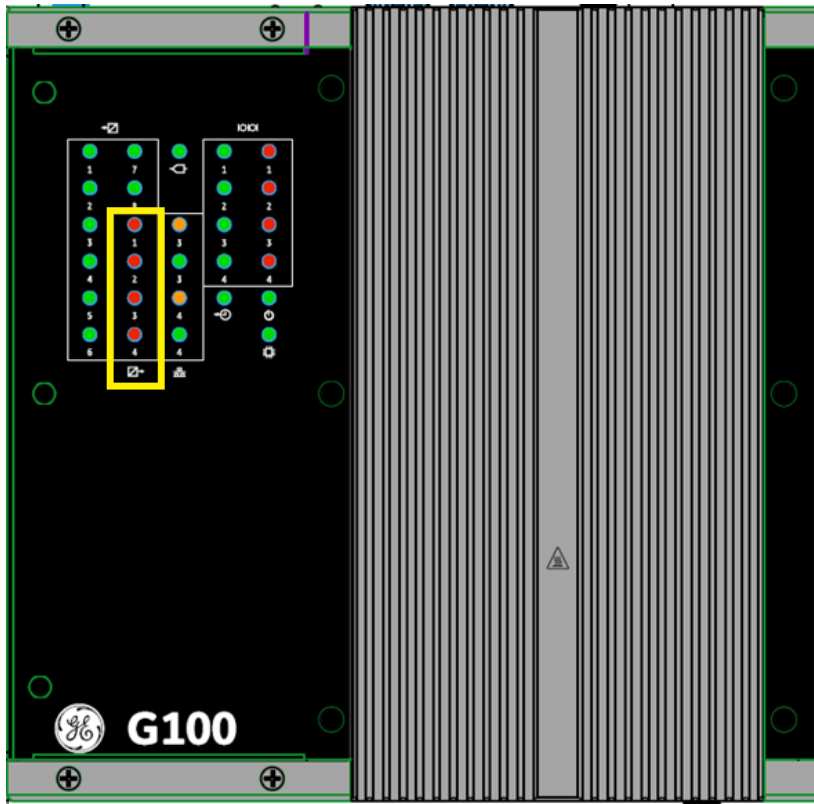

The DO operation types are LATCH_ON and LATCH_OFF.

At runtime, commands received as CLOSE/PULSE_ON/ON are all translated to LATCH_ON, and commands received as TRIP/PULSE_OFF/OFF are all translated to LATCH_OFF.

Analog DC Inputs (AI): 4

Each AI channel is configurable via internal jumpers as Full Scale either +5 VDC (Default setting) or 20 mA. The resolution is 12-bit plus sign, self calibrating.

AI wiring is via a pluggable connector, pitch 3.5mm x 12 pins, located on the top side panel:

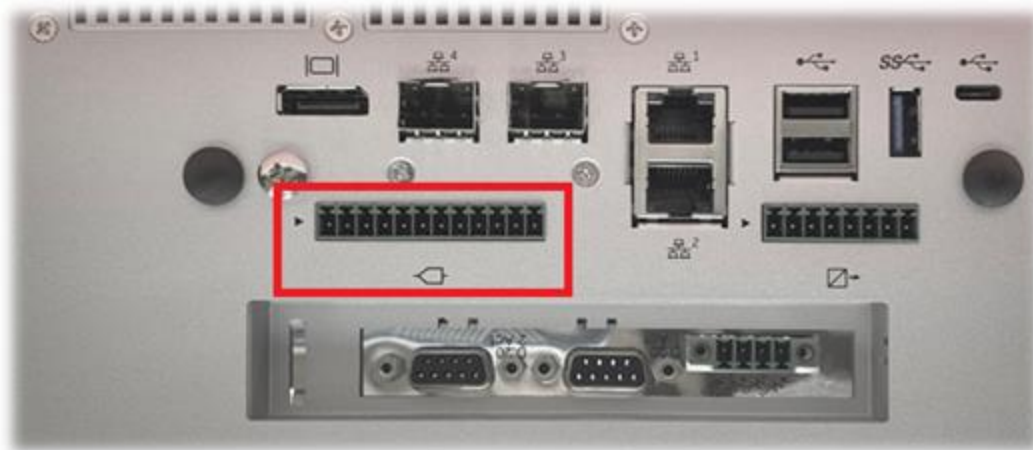

The small arrow on the left indicates PIN 1.

Table 6: GPIO AI connector pin assignments

PIN NO.	DESCRIPTION
1 (arrow)	A_VIN0+/IIN0 +
2	A_VIN0 -
3	AGND_ISO_CHS
4	A_VIN1+/IIN1 +
5	A_VIN1 -
6	AGND_ISO_CHS
7	A_VIN2+/IIN2 +
8	A_VIN2 -
9	AGND_ISO_CHS
10	A_VIN3+/IIN3 +
11	A_VIN3 -
12	AGND_ISO_CHS



NOTE

In the pin description, “_CHS” is the shield connection for each AI channel (all CHS are common wired internally).

The jumpers for Voltage or Current input selection are located on the GPIO internal board and their settings are as follows:

Jumper JAI12~JAI15	
1-2 (Default)	Voltage
2-3	Current

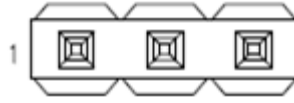

Table 7: GPIO AI Voltage / Current selection jumper

Jumper JAI12	DESCRIPTION
1-2 (Default)	V_IN_CH_1
2-3	I_IN_CH_1

Jumper JAI13	DESCRIPTION
1-2 (Default)	V_IN_CH_2
2-3	I_IN_CH_2

Jumper JAI14	DESCRIPTION
1-2 (Default)	V_IN_CH_3
2-3	I_IN_CH_3

Jumper JAI15	DESCRIPTION
1-2 (Default)	V_IN_CH_4
2-3	I_IN_CH_4

AI sampling is indicated at runtime via one LED (for all AI channels) located on the front side of the G100:

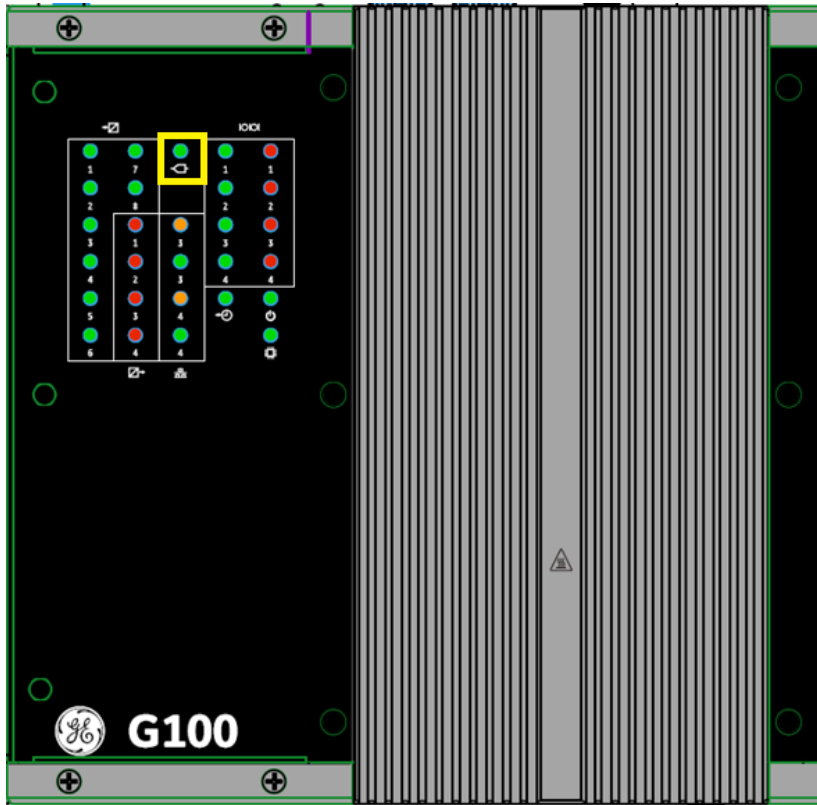

D.20 Link Connections

G100 can communicate with D20 peripheral modules.

To communicate with D20 peripheral I/O modules the G100 requires the installation and configuration of the optional D.20 HDLC PCIe card.

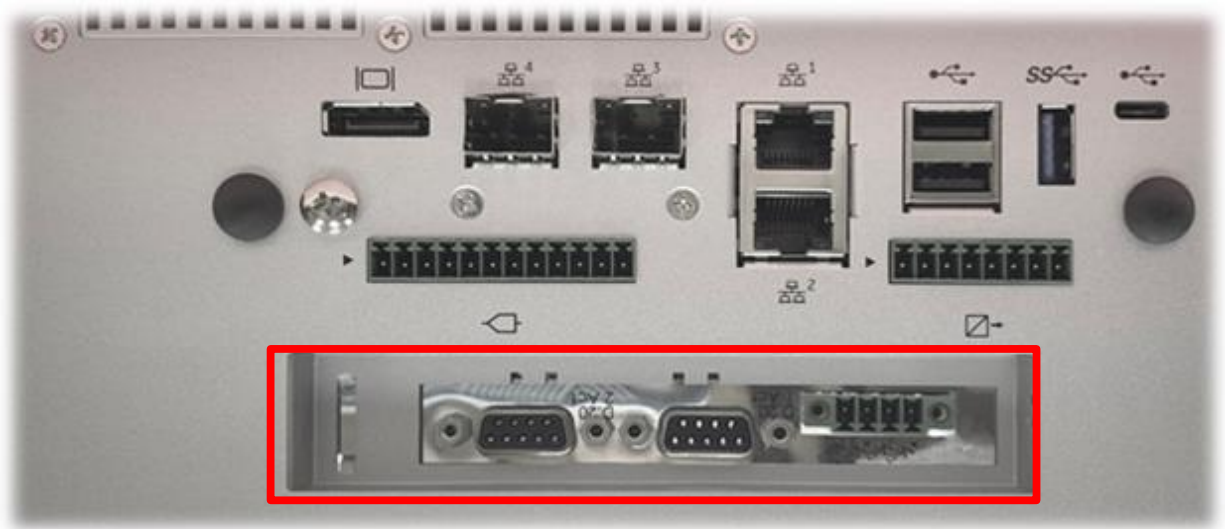

D.20 Communications between the D.20 HDLC PCIe card and the D20 peripheral I/O modules are carried over a proprietary high-speed, high-level data link control (HDLC) protocol called the D.20 Link.

The D.20 HDLC PCIe card supports two D.20 Link communications ports. The G100 system can be ordered from the factory with the D.20 HDLC PCIe card pre-installed using the Product configurator through the Online Store or can be installed infield by ordering the D.20 HDLC PCIe card as an accessory from the MCP Substation Gateway Spare Parts and following the "Installation of optional D.20 HDLC Card" on page 27.



G100 is limited by performance to communicate with up to **60** D.20 peripheral I/O modules. Please consider the G500 product for more D20 peripheral I/O modules (up to the maximum of 120).

G100 D.20 HDLC PCIe card

The D.20 HDLC PCIe card is equipped with a Power Pass Through connector, two D.20 ports and four LEDs.

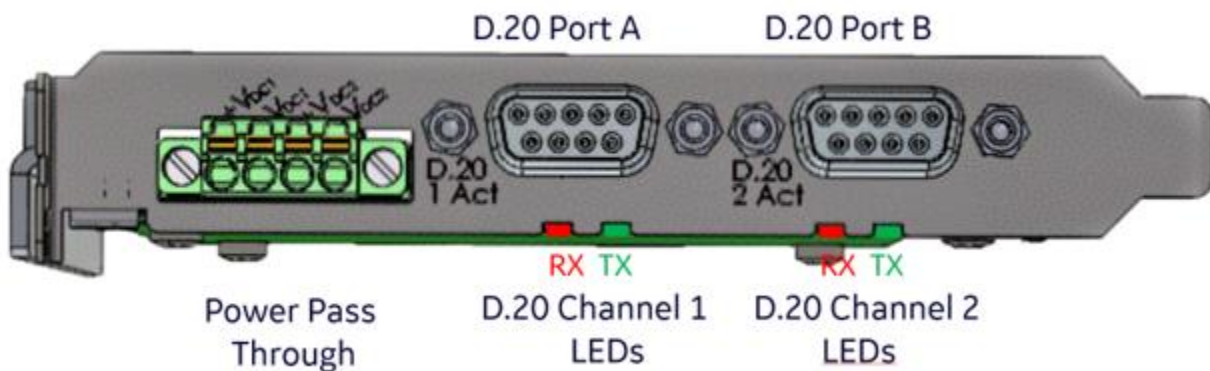

The Power Pass Through connector allows the D.20 peripheral connected to the D.20 Link to be powered through the D.20 port. The Power Pass Through requires one or two external power supplies to be connected. Refer to "Supplying power through the D.20 Link" on page 29 section for further details.

Two sets of LEDs are present on the D.20 HDLC PCIe card to indicate activity status. The first set of LEDs, on the left labeled D.20 1 Act, shows the transmit and receive activity on D.20 Channel 1 and the second set to show activity on D.20 Channel 2 on the right labeled D.20 2 Act. The receive LEDs will flash red and the transmit LEDs will flash green.

The D.20 HDLC PCIe card has two D.20 ports. Each port contains D.20 Channel 1, D.20 Channel 2, DC Supply 1, and DC Supply 2. For D.20 port A, the above signals are always available. For D.20 port B, D.20 Channel 1 and D.20 Channel 2 are configurable but DC Supply 1 and DC Supply 2 are always available. Refer to Table 1: D.20 Port A and B pin out and configuration options and Table 2: Default D.20 Relay settings. D.20 Port B settings are software controlled and are accessible through the Settings GUI on your G100. Refer to SWM0101 for further details on configuration.

Table 8: D.20 Port A and B pin out and configuration options

Pin Number	D.20 port A	D.20 Port B	
1	No Connection	No Connection	
2	D.20 Channel 1 TX/RX	D.20 Channel 2 TX/RX	OPEN
3	D.20 Channel 1 TX/RX -	D.20 Channel 2 TX/RX -	OPEN
4	VDC1 +	VDC1 +	
5	VDC1 -	VDC1 -	
6	D.20 Channel 2 TX/RX	D.20 Channel 1 TX/RX	OPEN
7	D.20 Channel 2 TX/RX -	D.20 Channel 1 TX/RX -	OPEN
8	VDC2 +	VDC2 +	
9	VDC2 -	VDC2 -	

End of link termination is required at each end of the D.20 Link and is critical for proper operation. The D.20 HDLC PCIe card has two relays which control the End of Link termination, one for each D.20 Channel. Refer to Table 2: Default D.20 Relay settings. End of Link termination settings are software controlled and are accessible through the Settings GUI on your G100. Refer to SWM0101 for further details on configuration.

Table 9: Default D.20 Relay settings

D.20 Relay setting	Default setting
End of Link termination on channel 1	Enabled
End of Link termination on channel 2	Enabled
D.20 channel 1 to D.20 port B connection	Disabled
D.20 channel 2 to D.20 port B connection	Disabled

Supplying power through the D.20 Link

Power is typically supplied to peripheral devices directly through the WESTERM boards or inject power into the D.20 link using the D.20 DC Interface module (520-0154). However, with the D.20 HDLC PCIe card the Power Pass Through connections can be utilized to inject power into the D.20 link to supply power to peripheral devices through the D.20 ports.

One or two independent power supplies can be connected to DC Supply 1 (VDC1) and DC Supply 2 (VDC2). DC Supply 1 (VDC1) is connected through to pins 4 and 5 on both D.20 ports (DB9 connector), respectively DC Supply 2 (VDC2) is connected to pins 8 and 9.

The DC supply load on the D.20 port by the peripheral link must not to exceed 3.5A and 20 -60 VDC



NOTE

The Power Pass Through connections are protected to 3.5A

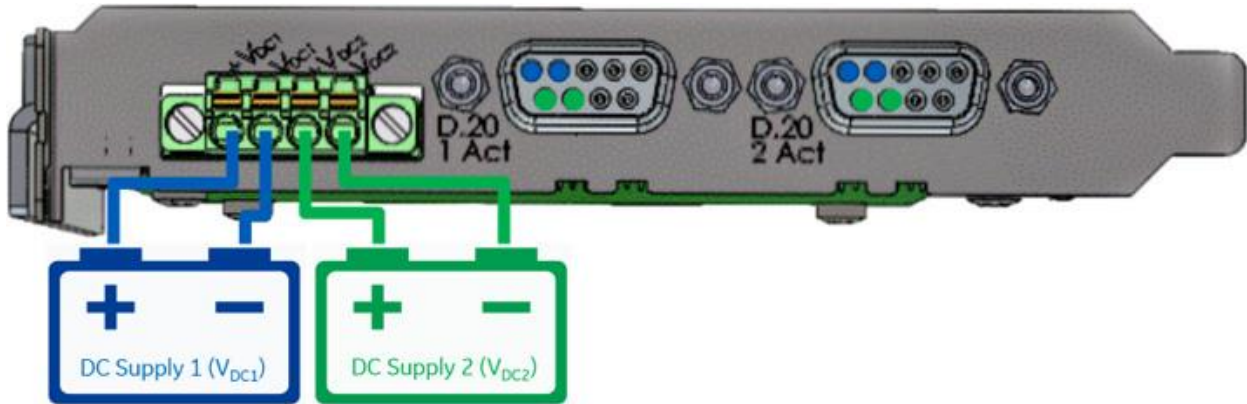

D.20 Peripheral Types

D.20 Peripheral I/O modules are intelligent modules containing an on-board microprocessor. They are configured as slaves to the G100. In this way, specific I/O processing is distributed throughout the to the appropriate I/O module.

There are four types of I/O peripherals supported by the D.20 HDLC PCIe:

- D20A analog input
- D20S digital inputs
- D20K digital output
- D20C combination input/output

Optional high-voltage peripherals are also available.

Redundant D.20 communication channels are available on all peripherals. To utilize this function redundant D.20 LAN cards are required to be installed on the D.20 Peripheral I/O modules. D.20 A, S and K Peripheral I/O modules require 540-0207 and D.20 C requires 540-0209.

The D.20 HDLC PCIe card is only compatible with CCU BASE and PCOMMON v3.00 or higher.



NOTE

Refer to Peripheral Compatibility with the D.20 HDLC PCIe card section in this manual for complete list of D.20 Peripheral I/O compatibility.

For further information on I/O peripherals, see the D20/D200 Installation and Operations Guide (part number 994-0078); see section: Connections and Configuration.

Peripheral compatibility with the D.20 HDLC PCIe card

Use the tables in this section to check compatibility with existing D.20 Peripheral I/O modules and devices.

Table 10: D20A Analog Input Module Compatibility

Component	GE Item #	Description	Compatible release	Date of release
WESDAC	511-0101	WESDAC D20A TYPE 1 VERSION 1	REL 21-higher	April 1998
WESDAC	511-0102	WESDAC D20AHV	All	
WESDAC	511-0103	WESDAC D20AHV2	All	
WESTERM	517-0163	WESTERM D20A TYPE 1 VERSION 1	All	
	517-0178	WESTERM D20 AD	All	
Redundant D.20 LAN	540-0207	WESDAC D20 ASK D.20 I/F	All	
PCOMMON	306	PCOMMON v3.06	All	
	305	PCOMMON v3.05	All	
	301	PCOMMON v3.01	All	
	300	PCOMMON v3.00	All	

Table 11: D20S Status Input Module Compatibility

Component	GE Item #	Description	Compatible release	Date of release
WESDAC	507-0101	WESDAC D20S TY1 VER 1	REL 18-higher	March 1998
WESDAC	507-0103	WESDAC D20SHV2	All	
WESTERM	517-0165	WESTERM D20S TYPE 1 VERSION 1	All	
Redundant D.20 LAN	540-0207	WESDAC D20 ASK D.20 I/F	All	
PCOMMON	306	PCOMMON v3.06	All	
	305	PCOMMON v3.05	All	
	301	PCOMMON v3.01	All	
	300	PCOMMON v3.00	All	

Table 12: D20K Control Output Module Compatibility

Component	GE Item #	Description	Compatible release	Date of release
WESDAC	508-0101	WESDAC D20K TYPE 1 VERSION 1	REL 17-higher	April 1998

WESDAC	508-0102	WESDAC D20KHV	All	
WESTERM	517-0164	WESTERM D20K TYPE 1 VERSION 1	All	
Redundant D.20 LAN	540-0207	WESDAC D20 ASK D.20 I/F	All	
PCOMMON	306	PCOMMON v3.06	All	
	305	PCOMMON v3.05	All	
	301	PCOMMON v3.01	All	
	300	PCOMMON v3.00	All	

Table 13: D20C Combination Input/Output Module Compatibility

Component	GE Item #	Description	Compatible release	Date of release
WESDAC	504-0002	WESDAC D20C+	REL 20-higher	September 1996
WESDAC	504-0003	WESDAC D20CHV	All	
WESTERM	517-0180	WESTERM D20 CD	All	
Redundant D.20 LAN	540-0209	WESDAC D20C D.20/WESMAINT I/F	All	
PCOMMON	305	PCOMMON v3.05	All	
	300	PCOMMON v3.00	All	

Table 14: Repeater/Splitter Compatibility

Component	GE Item #	Description	Compatible release	Date of release
REPEATER	520-0117	D.20 COMMUNICATION INTERFACE	REL 13 -higher	April 1999
SPLITTER	520-0118	D.20 FIBER OPTIC SPLITTER 4-WA	REL 11 -higher	April 1999
GFO	520-0148	WESDAC D.20 RS485/GFO I/F 48V	REL 09 -higher	December 1994

D.20 Connection topologies

The D.20 HDLC PCIe card supports the below D.20 topologies:

- Single D.20 terminated, single link
- Dual D.20 link terminated
- Single D.20 link, redundant LAN
- Redundant D.20 link, redundant LAN

Single D.20 terminated, single link

Figure 4: Single D.20 terminated, single link - Topology

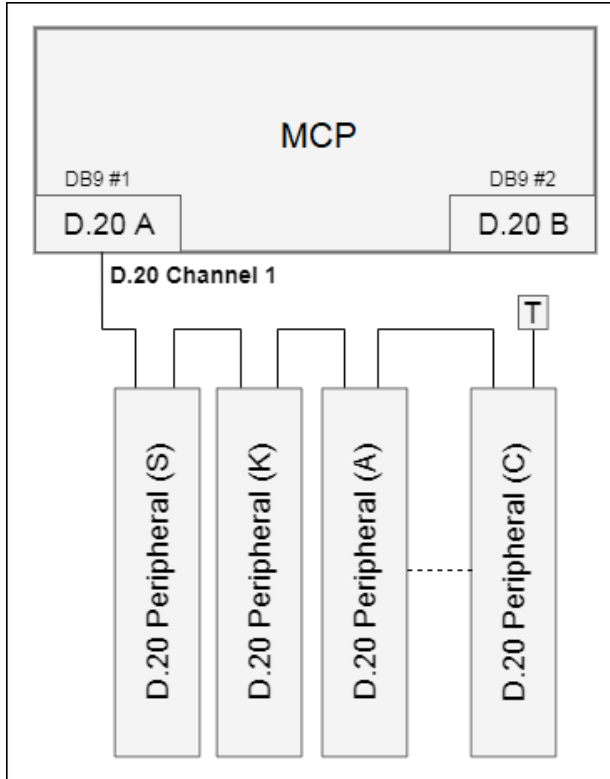

D.20 redundant LAN daughter card can optionally be installed with the corresponding configuration (Single Link) in DSAS.

The last D.20 peripheral must be terminated with D.20 terminator (GE part#: 977-0049).

Table 15: Single D.20 terminated, Single Link - Default settings

Function	State
End of Link - D.20 Channel 1	ON
End of Link - D.20 Channel 2	ON
Port B - D.20 Channel 1 (pin 6/7)	OFF
Port B - D.20 Channel 2 (pin 2/3)	OFF

Dual D.20 link terminated

Figure 5: Dual D.20 link terminated - Topology

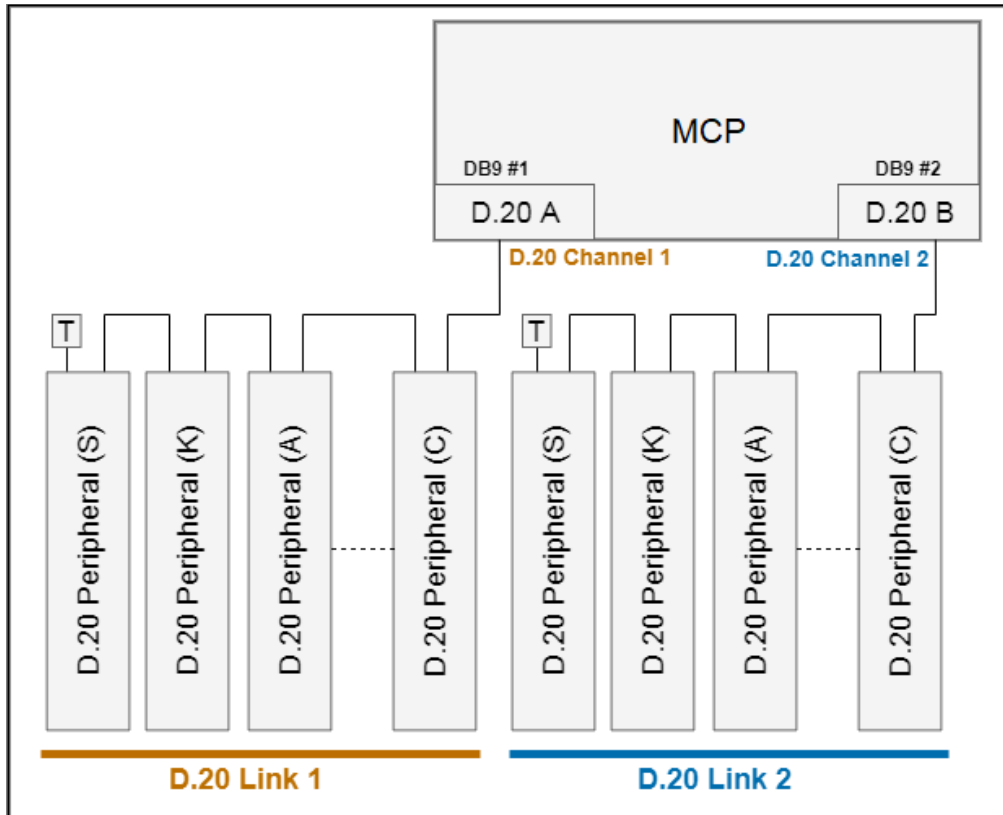

D.20 redundant LAN daughter card can optionally be installed with the corresponding configuration (Redundant Link) in DSAS.

The last D.20 peripheral must be terminated with D.20 terminator (GE part#: 977-0049).

Table 16: Dual D.20 link terminated – Default settings

Function	State
End of Link - D.20 Channel 1	ON
End of Link - D.20 Channel 2	ON
Port B - D.20 Channel 1 (pin 6/7)	OFF
Port B - D.20 Channel 2 (pin 2/3)	ON

Single D.20 link, redundant LAN

Figure 6: Single D.20 link, redundant LAN - Topology

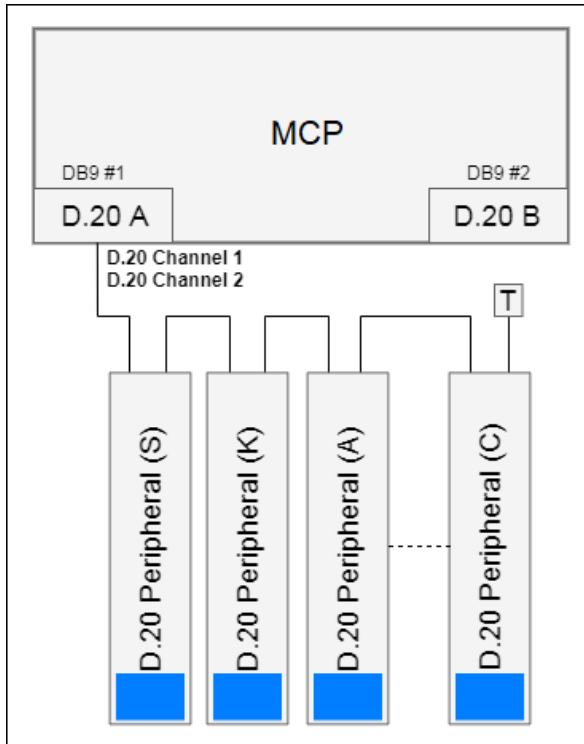

D.20 redundant LAN daughter card (GE part#: 540-0209 for D.20C and GE part#: 540-0207 for D.20A,S,K) must be installed with the corresponding configuration (Redundant Link) in DSAS.

The last D.20 peripheral must be terminated with D.20 terminator (GE part#: 977-0049).

Table 17: Single D.20 link, redundant LAN - Default settings

Function	State
End of Link - D.20 Channel 1	ON
End of Link - D.20 Channel 2	ON
Port B - D.20 Channel 1 (pin 6/7)	OFF
Port B - D.20 Channel 2 (pin 2/3)	OFF

Redundant D.20 link, redundant LAN

Figure 7: Redundant D.20 link, redundant LAN - Topology

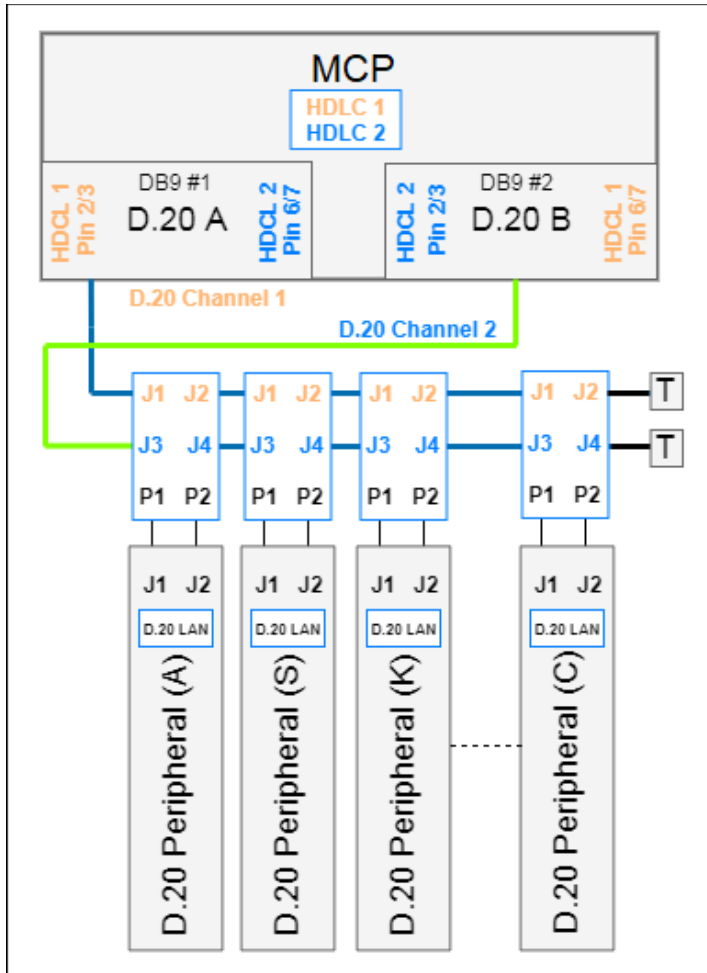

D.20 redundant LAN daughter card (GE part#: 540-0209 for D.20C and GE part#: 540-0207 for D.20A,S,K) must be installed.

D.20 link adapter must be installed on each D.20 peripheral (GE part#: 540-0313)

The D.20 Link crossover cable must be installed from CCU D.20 Port B to peripheral link (GE part#: 977-0561)

The last D.20 peripheral must be terminated with D.20 terminator (GE part#: 977-0049)

Table 18: Redundant D.20 link, redundant LAN - Default settings

Function	State
End of Link - D.20 Channel 1	ON
End of Link - D.20 Channel 2	ON
Port B - D.20 Channel 1 (pin 6/7)	ON
Port B - D.20 Channel 2 (pin 2/3)	ON

Serial ports (RS232/485, RJ45, labelled 1-4)

The G100 has 4 Built-in Serial ports available as RJ45 connectors on the bottom panel of the unit.



Each serial port has LED activity (Tx/Rx) indicators on the front panel:

- Tx Activity (Green)
- Rx Activity (Red)

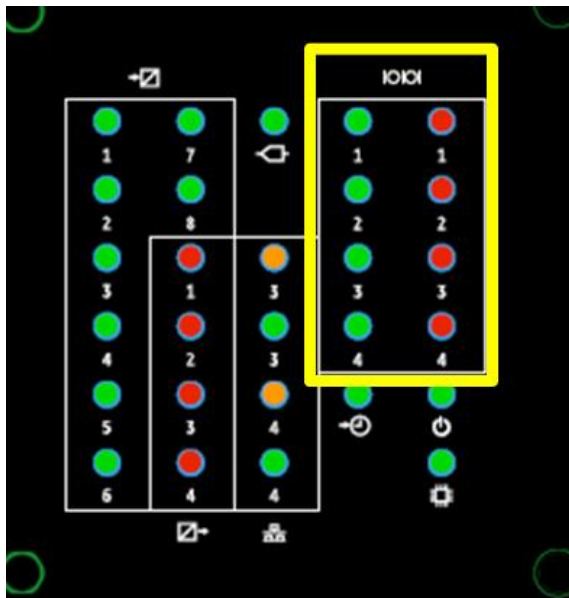

The serial ports are isolated from the rest of the system at 1.5KV AC / 2.1KV DC.







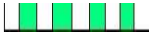

The serial ports support the following communication modes:

- RS232
- RS485 2-Wire

For every port an Rx Termination Resistor of 120 Ohms can be enabled through the software interface.

The pin assignment of the Serial Interfaces is dependent on the operation mode selected for the interface:

Table 19: RJ45 Pin outs for Serial Port Signals

EIA568	TIA/EIA 568A	RJ45 Pin out	RS232	RS485 2-Wire
		1	Rx	D-
		2	CTS	D+
		3	Tx	-
		4	GND	GND
		5	IRIG-B OUT	IRIG-B OUT
		6	RTS	-
		7	-	-
		8	DCD	-



IRIG-B OUT is available only when an IRIG-B IN signal is connected. The G100 does not have an internal IRIG-B signal generator.

The supported levels are compliant to TTL by a load of 120Ohm or higher. It is current limited and protected against damage by short to GND (Pin 4).

Figure 8: Modular connector 8P8C (RJ45) pins

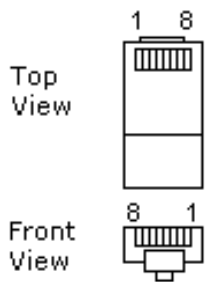

Shielded twisted pair cables shall be used for wiring.

RS-485 Serial Connections

The G100 can be configured to communicate with RS-232 or RS-485 2-wire type devices using the 4 Built-in Serial Ports.

Each serial port can be independently configured through the Settings GUI. All port configurations persist through a power cycle and when power is lost.

In RS-485 mode End of Link Termination (120 Ohm) can be enabled through the Settings GUI.



When enabled in Settings, End of Link Termination is active only when the device is powered on and applications are running. This has no operational impact because the G100 is meant to act as a master to other devices

The cables must be shielded and the shield of each RS-485 cable section should be grounded at one end only. This prevents circulating currents and can reduce surge-induced current on long communication lines.

Signal ground on pin4 is to be considered different than shield on cable.

When creating custom cables, it is recommended to only wire the required pins.

The following diagram illustrates how to wire the G100 units using RS485 2-wire.

Figure 9: G100 connection using RS485 2-wire

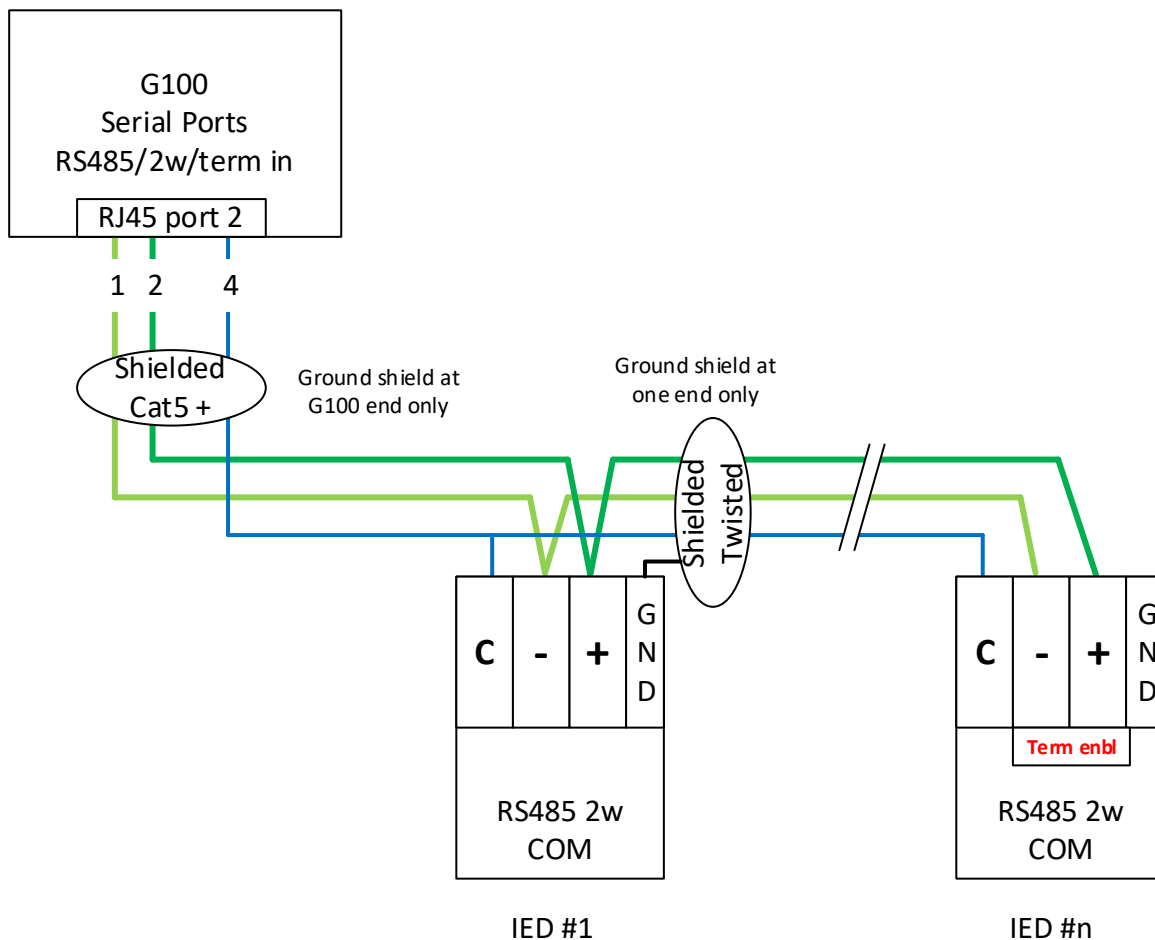

Default Serial Maintenance port (port 4, RS232)

When running the *Factory Default* configuration, G100 has one serial maintenance port enabled, which is **always allocated to Port 4**.

This maintenance port allows users to perform the following workflows:

- Intercept POST and access UEFI settings (useful when a KVM is not connected to G100)
- Access Shell for maintenance actions after the applications started

The following documents provide details for each workflow:

- Configuring UEFI Settings on G100 User Guide (SWM0122)
- G100 Substation Gateway Quick Start Guide (SWM0116)
- MCP Substation Gateway Software Configuration Guide (SWM0101)

NOTICE

While the serial maintenance port is enabled as #4, this same port cannot be used for other applications.

The serial maintenance port can be disabled as following:

- In UEFI for the POST access only. Make sure that UEFI is set to RS232.
- In Settings for Shell access and use by other runtime applications.

If the serial maintenance port is disabled, users can still access the device using either the KVM or Ethernet ports.

UEFI allocation of the serial maintenance port is intended for UEFI access in absence of KVM (during startup), and it is different than Settings serial maintenance port "shell" access (during normal operation).

NOTICE

If the serial maintenance port was disabled, and the IP addresses are not known – then access can be done using KVM.

NOTICE

Do not change maintenance port assignment in UEFI from port # 4 !

Ethernet ports

The top panel of the G100 provides 4 independent Ethernet ports, labelled 1 to 4.

NOTICE

The G100 Ethernet ports use separate MAC addresses.

The G100 Ethernet ports cannot be configured as Redundant Single MAC.

G100 does not support PRP (Parallel Redundancy Protocol IEC62439-3).

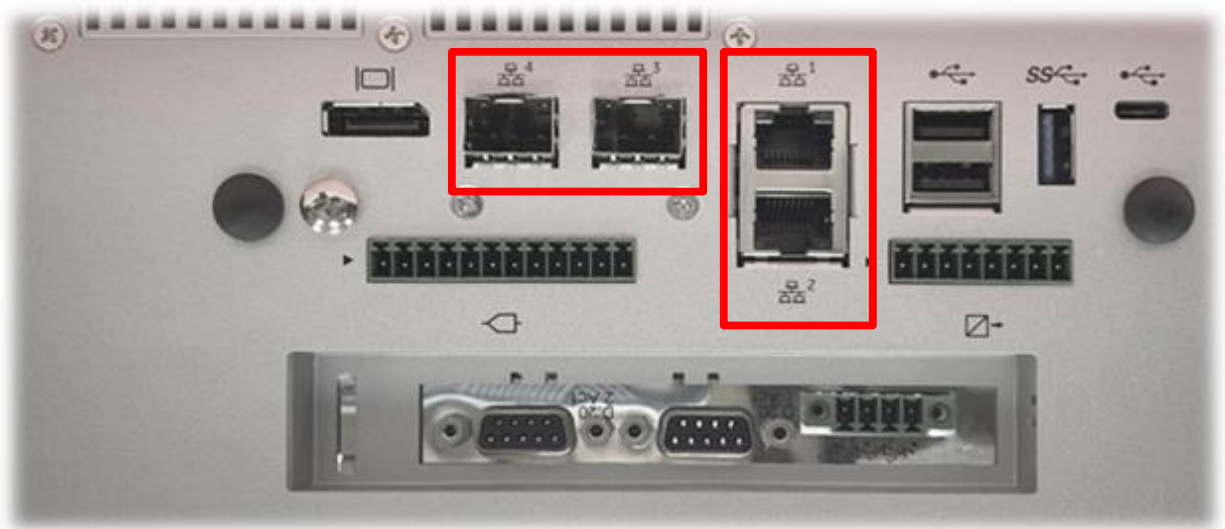

TP Ethernet ports and LED indications (labelled 1, 2)

Ports 1 and 2 are RJ45 Copper (RJ45 10/100/1000BASE-TX) with separate NICs (LAN1/2).

Each RJ45 port has LED indicators inside the RJ45 connector:

- Activity (Green)
- Link (Orange)

Each RJ45 port is isolated to 1.5KV AC / 2.1KV DC

SFP Ethernet ports (labelled 3, 4)

Ports 3 and 4 are SFP with separate NICs (LAN3/4).

Into each slot an SFP module can be inserted.

Each SFP port has LED indicators on the front panel:

- Activity (Green)
- Link (Orange)

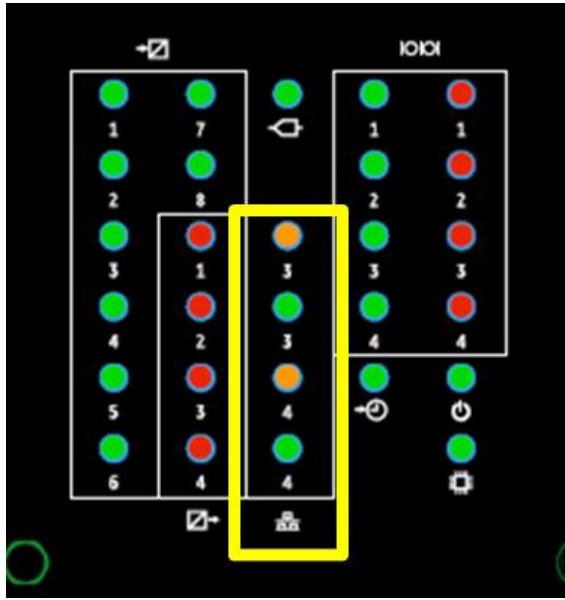

Each SFP port is isolated to 1.5KV AC / 2.1KV DC.

For corresponding SFP modules and order codes see following sections in this document:

Order Code

Spares and Accessories

The following table presents in detail the SFP modules supported by the G100.

Table 20: SFP modules supported by the G100

Item	Description	Manufacturer	Mfg Part
580-3784	SFP Module 100BASE-FX LC TRANSCEIVER OPTICAL	AVAGO	HFBR-57E0APZ
580-3785	SFP Module 1000BASE-SX LC TRANSCEIVER OPTICAL	AVAGO	AFBR-5710ALZ
		FINISAR	FTLF8519P3BTL
580-3786	SFP Module 1000BASE-TX RJ45 TRANSCEIVER COPPER	FINISAR	FCLF8522P2BTL
		FOXCONN	ABCU-5730ARZ
		FOXCONN	ABCU-5731ARZ
0123-0004	SFP Module 10/100BASE-TX RJ45 TRANSCEIVER COPPER	AXCEN	AXFE-R1S4-05H3
580-3787	SFP Module 1000Base-LX LC TRANSCEIVER OPTICAL SINGLE-MODE 5km 1310nm -40 to 85C	FOXCONN (AVAGO)	AFCT-5715ALZ

The cables required to make physical connections to the G100 are as follows:

Table 21: Ethernet cables required by the G100

Media	Designation	Cable	Connector
Twisted Pair Ethernet	100/1000BASE-TX	UTP (Unshielded Twisted Pair) - Cat-5 or better	RJ45
Fiber optic	100BASE-FX	Fiber optic cable multimode	LC
Fiber optic	1000BASE-SX	Fiber optic cable multimode	LC

CAUTION This product contains components rated as Class 1 Laser Products.



G100 cannot read the SFP model automatically. Each SFP Ethernet port must be configured correctly to match the installed SFP type, in the Settings utilities (*mcpcfg, Settings GUI*) – please see the *G100 Quick Start Guide* and *MCP Software Configuration Guide* documents.

A device reboot is required for new SFP settings to take effect.

Time synchronization IRIG-B input (2 pin connector)

The bottom panel of the unit provides one IRIG-B input connector.

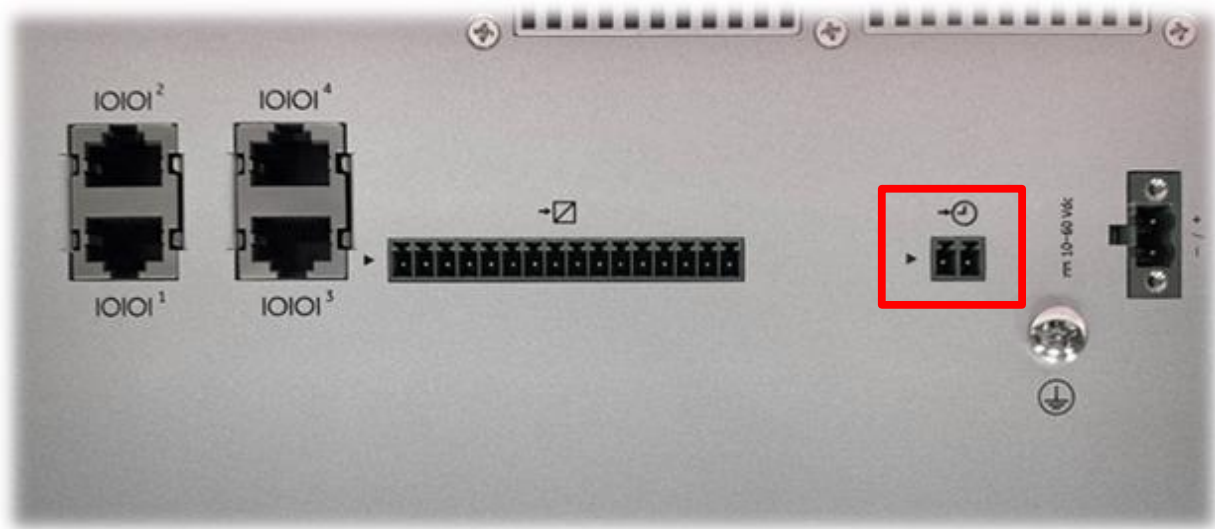
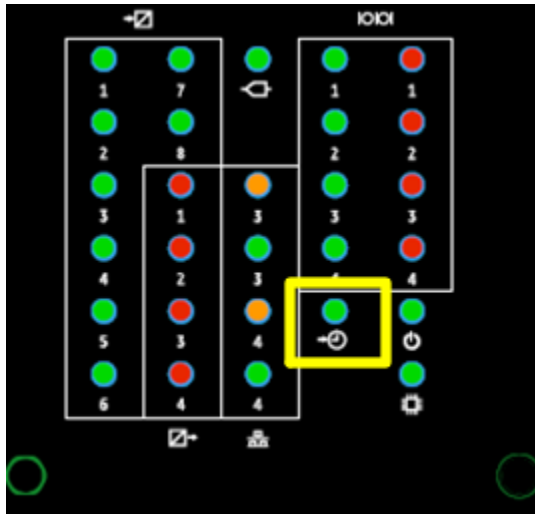

Table 22: IRIG-B input connector pin assignments

PIN NO.	DESCRIPTION
1 (arrow)	SIGNAL
2	GND

This input can be used to synchronize the precision timer of the unit. The supported IRIG-B formats are B002 and B006.

Presence of an IRIG-B signal is indicated by one LED located on the front panel:



When configured as B006 the clock requires a corresponding configuration where the year and quality are included in the IRIG-B signal. If the clock is not configured to provide the year the G100 will show the year 2000.

This Port is isolated from the rest of system with an isolation voltage of 1.5kV AC / 2.1kV DC.

The supported levels are compliant to TTL or TIA232, selectable by an internal jumper:

Green PIN HEADER 1x3 Male 180° 2.0mm DIP



Table 23: IRIG-B input signal selection TTL/RS-232

Jumper JIRIGB1	DESCRIPTION
1-2	TTL
2-3	RS232

NOTICE

G100 does not support PTP IEEE1588.

NTP and SNTP are supported.

DP Display Port

The top panel of the unit provides one DisplayPort™ connector.

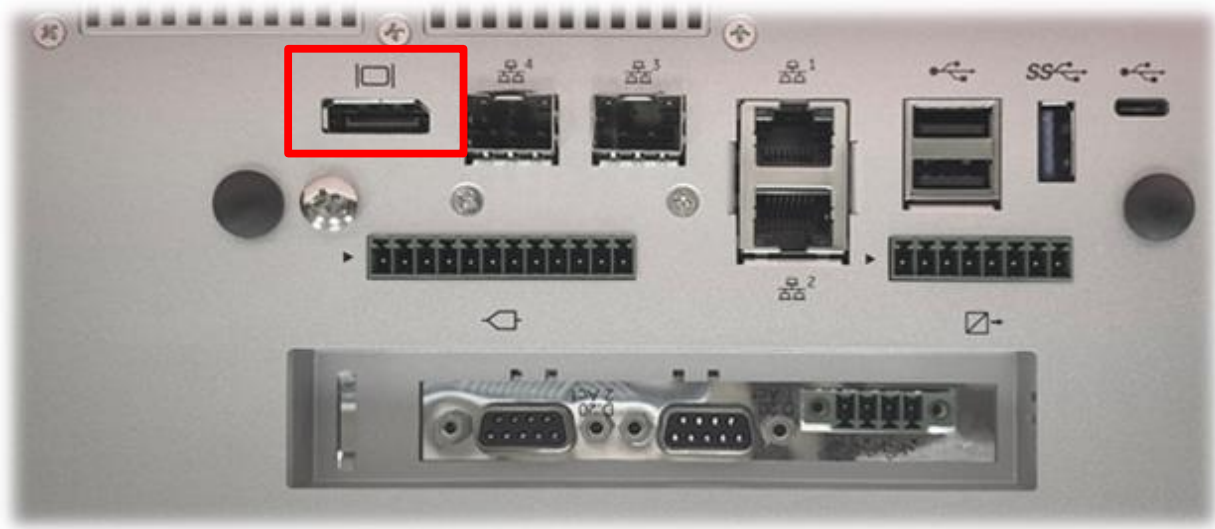

The interface is DisplayPort™ Version 1.2 and DP++ compliant which is used mainly to enable installation personnel to connect a display for the initial configuration of the device, or a Local Runtime HMI display.



NOTE

Multi Stream Transport (MST) for multiple attached displays is not supported.

The DisplayPort™ is fused internally. For normal operation don't exceed 0.5 A.

Users are recommended to use passive DP++ to HDMI and passive DP++ to DVI-D. Use of active adapters is not encouraged as they limit higher frequency refresh rates, and limit display sizes.



NOTE

G100 doesn't support Touch Screen Panel controls due to the absence of external vendor USB drivers. It's recommended to use a Windows Panel PC and the Remote HMI application instead.

USB ports



The top panel of the unit provides the following USB ports:

One USB 3.0 type A connector, mainly used to enable maintenance personnel to connect their equipment and storage devices for software updates.

The USB 3.0 A port is fused internally. For normal operation don't exceed 0.9 A per connector.

The maximum cable length for USB 3.0 cables is 3m (=118in).

Using longer cables than specified for each port might result in data loss.

Two USB 2.0 Type A connectors. Main purpose of these connectors is to enable installation personnel to connect Mouse, Keyboard and equivalent equipment for initial configuration of the device.

Each USB 2.0 A connector is fused separately. For normal operation don't exceed 0.9 A per connector. The cumulative current draw of all four ports is limited to 1A due to thermal and power budget restrictions.

The maximum cable length for USB 2.0 cables is 3m (=118in).

The USB Type C connector is for future applications, currently not used. Please do not connect external devices to it.

Internal Buzzer

The G100 has an internal buzzer, which is intended for local and close proximity general purpose usage.



This buzzer has a very low volume and as such is not suitable for critical operators' notifications.

The Local HMI and the DO points in the database can operate the buzzer, subject to above note on low sound level.

Home Dir	Point ID	Point Reference	Point Description
SS00001	-2021	DisableAllControls	DisableAllControls
SS00001	-204	Disable Buzzer	Disable Buzzer
SS00001	-204	Buzzer Sound ON	Buzzer Sound ON

Chapter 5 - Specifications

G100 Product Specifications

System

Processor	Intel Atom X5-E3930 1.3GHz Processor
Memory	8GB SoDIMM 204 pin DDR3L (up to 1866MHz)
Storage	16GB mSATA SSD
Real Time Clock (RTC)	When powered off, the real-time clock remains active for 5 days
Operating system	Predix Edge OS (Kernel 4.14)
LED indicators	Power indicator, CPU Status indicator, IRIG-B Input indicators, 2x SFP Ethernet port indicators, 2x TP Ethernet port indicators, 4X Serial port indicators, 8x DI channel indicator, 4x DO channel indicator, AI sampling indicator

Communications

Ethernet connections	<p>2 RJ45 Ethernet ports + 2 SFP modules</p> <p>1000BASE-LX 850nm 5km (LC fiber single-mode)</p> <p>100BASE-FX 1300nm 2km (LC fiber single-mode)</p> <p>100BASE-FX 1300nm 15km (LC fiber single-mode)</p> <p>100/1000BASE-TX (RJ45 copper medium, Cat-5 or better)</p> <p>100BASE-FX (LC fiber multimode)</p> <p>1000BASE-SX (LC fiber multimode)</p>
Serial communications	<p>4x serial interfaces accessible via individual RJ45 connectors</p> <p>Serial interfaces use 16550 compatible UART.</p> <p>Support baud rates 300, 600, 1200, 2400, 4800, 9600, ... 921k.</p> <p>Software controlled mode of operation between RS232 or RS485 2-wire.</p> <p>Software controlled termination resistor (120 ohm) for RS485 mode (termination is not active while powered off).</p> <p>All software selection persist when power cycled.</p> <p>IRIG-B available on all serial interfaces.</p>

D.20 Link HDLC Communications	A dual channel card is available to communicate D.20 Link protocol to up to 60 D20 Peripherals per channel. Each channel communicates at 250kbps. Channels are isolated from each and from other internal circuits.
Time synchronization	IRIG-B (TTL) Input Connector available as 2 positions removable Phoenix terminal block on bottom panel
Video Output	DisplayPort (DP) version 1.2 available on top panel
USB Ports	1x USB 3.0 Type A (male) on top panel 2x USB 2.0 Type A (male) on top panel 1x USB 2.0 Type C (male) on top panel (Future use)

Electrical

G100 rated input	Nominal 12/24/48 VDC $\pm 10\%$, 5A/2.5A/1.25A Minimum/Maximum DC voltage: 10 VDC to 60 VDC
GPIO (DI/DO/AI)	Isolation rating: 820V _{RMS} /1150V _{DC}

G100 Environmental Specifications

Temperature and Humidity

Storage	-40°C to 85°C
Operating Conditions	-40°C to 70°C
Humidity	5%~90% relative humidity, non-condensing

Ingress Protection (IEC 60529)

IP40 (protected from most wires and slender screwdrivers greater than 1 millimeter).

Mechanical Specifications

Weight

Part	Weight in kg
G100	2.47
D.20 Link HDLC PCIe Card	0.18
Packaging + accessories	2.15

Dimensions

All dimensions are in mm

200 (L) x 90(W) x 195(H) mm

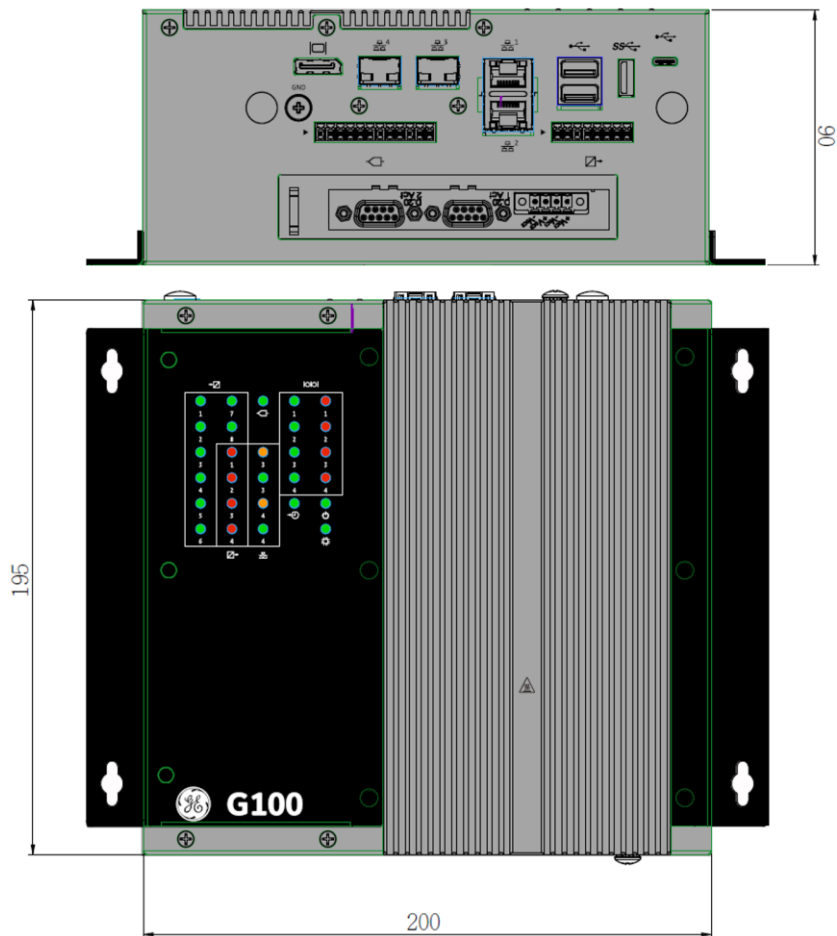

Storage recommendations

Storage conditions

Always store the G100 in an environment compatible with operating conditions. Recommended environmental conditions for storage are:

- Temperature: -40°C to +85°C
- Relative humidity: 5% to 95%, non-condensing

Exposure to excessive temperature or other extreme environmental conditions might cause damage and/or unreliable operation.

To avoid deterioration and early failure of electrolytic capacitors, power up units that are stored in a de-energized state once every 12 months, for one hour continuously.

Chapter 6 - Removing the G100 from Service

Before you begin installing and using the G100, review the information in this chapter, including the following topics:

When the G100 is to be removed from service, it is necessary to:

- Remove the configuration data and sensitive information from:
 - The G100
 - The PC used to remotely configure the G100
- Dispose of the equipment.

Remove configuration data and sensitive information from the G100

In the event that it is necessary to remove the configuration data and sensitive information from the G100 (for example, the G100 is being disposed of or being returned for maintenance [i.e., RMA]), this chapter provides the data removal procedure.

For additional information, please refer to “SWM0123 G100 Secure Deployment User Guide”.

To remove configuration data and sensitive information from the G100:

1. For an RMA: GE recommends restoring the unit to factory default state using the procedure in Section 3 of TN0116 MCP Firmware Upgrade and Restore to Defaults Workflows.
2. For hardware decommissioning and disposal: GE recommends that you destroy the device as per NIST* recommendations.

* Publication 800-88 Revision 1. Guidelines for Media Sanitization, Recommendations of the National Institute of Standards and Technology:

<http://nvlpubs.nist.gov/nistpubs/SpecialPublications/NIST.SP.800-88r1.pdf>

Removing configuration data on a PC

When a PC application is used to configure the G100, configuration data resides on the data storage media (e.g., hard drives, memory cards, etc.) of the PC running the configuration application.

The G100 configuration data can be removed from the PC by either:

- Recommended: Physically removing and destroying the data storage media, or
- Using a program to securely wipe (that is, completely erase) the data storage media (that is, not just reformat or remove the names of the files from the file allocation table).

Appendix A – Standards & Compliance

Compliance Standards

The G100 complies with the tests listed below.

Standard	Description	Test Level / Class	Pass Criteria
IEC 62368-1	Audio/Video, Information And Communication Technology Equipment - Part 1: Safety Requirements	Per standard	
IEC 60068-2-1	Cold	-40°C for 16hours	A
	Cold start	1hour soak, 3 power ups every 10 mins	A
IEC 60068-2-2	Dry Heat	+70°C for 16hours	A
	Hot start	1hour soak, 3 power ups every 10 mins	A
IEC 60068-2-78	Damp Heat, steady-state	+40°C, 95%RH, non-condensing, 96hours	A
IEC 60068-2-6	Vibration (sinusoidal)	0.5g, 1 sweep, 3 axes, with EUT energized	A
IEC 60255-21-1		1g, 10 sweep, 3 axes, with EUT non-energized	
IEC 60068-2-27	Shock Response	5g, 3 +/- shocks, 3 axes, with EUT energized.	A
	Shock Withstand	15g, 3 +/- shocks, 3 axes, with EUT non-energized.	
IEC 60068-2-27	Bump (Non-operating test)	10g, 1k bumps, 6 axes, with EUT non-energized.	No damage, functions
IEC 60068-2-31	Drop & Topple	100mm non-energized	No damage, functions
IEC 60255-21-3	Seismic	1-35Hz; X axis: 7.5mm, 2g; Y axis: 3.5mm, 1g	A
EN 60255-27	Product safety requirements: information technology equipment	Impulse: 1/5kV _{PEAK} Dielectric: 820V _{RMS} /1150V _{DC} Insulation Resistance: >100MΩ	No damage, breakdown or flashover
CISPR22	Radiated RF Emission Conducted Emission	Radiated Emissions: 30 MHz to 6 GHz NA	Class A
IEC 61000-4-2 IEEE C37.90.3	Immunity to Electrostatic Discharge	8kV - Contact/15kV - Air	A
IEC 61000-4-3 IEEE C37.90.2	Immunity to Radiated RF	80 MHz- 3 GHz @ 10V/m (35V/m)	A
IEC 61000-4-4 IEEE C37.90.1	Immunity to Fast Transient Burst	4kV/5kHz	A/B

IEC 61000-4-5 IEEE 1613	Immunity to Surge	Power and Signal ports: 4/2/1/0.5kV	A/B
IEC 61000-4-6	Immunity to Conducted RF	10Vrms/150kHz-80MHz	A
IEC 61000-4-18 IEEE C37.90.1	Immunity to Damped Oscillatory	2.5kV/1MHz	A/B
IEC 61000-4-8	Immunity to Power Magnetic Field	100A/m @ 180s 1000A/m @ 3s	A
IEC 61000-4-11	Immunity to Voltage Dip and Interrupt	100% @ 5, 10-200msec (10msec increments)	A
IEC 61000-4-16	Immunity to Conducted CM Disturbances (DC-150kHz)	30Vrms & 300Vrms	A/B
IEC 61000-4-17	Ripple on DC power supply	10% AC ripple on DC Power Port	A
IEC 61000-4-29	Dip and Interrupt on DC power supply	Voltage Dips: 40%/70% for 0.01 sec Interruptions: 0% for 0.01 sec Variations: 85% to 120% for 10 sec	A

Appendix B – Warranty

Warranty

For products shipped as of October 1st, 2013, G100 warrants most of its GE manufactured products for 10 years. For warranty details including any limitations and disclaimers, see the GE Grid Solutions Terms and Conditions at:

<https://www.gegridsolutions.com/multilin/warranty.htm>

Appendix C – Glossary of terms used in this document

D

DP: Display Port

G

GUI: Graphical User Interface (also called Human Machine Interface – HMI)

GW / GTW: Gateway (in Substation Automation context)

H

HMI: Human Machine Interface (also called Graphical User Interface – GUI)

HMI Client: Client-side functionality that resides in the user's browser

HMI Server: Server-side functionality that resides on the G100 and provides services to the client-side browsers

HTTP: HyperText Transfer Protocol

HTTPS: Designated the use of HTTP but with a different default port and an additional encryption/authentication layer between HTTP and TCP

I

IED: Intelligent Electronic Device

IP: Internet Protocol

IRIG-B: Inter Range Instrumentation Group (IRIG) - an American standardized network time code format

L

LAN: Local Area Network

M

MAC: Media Access Control

MCP: Multifunction Controller Platform

N

NIC: Network Interface Card

NTP: Network Time Protocol

NVRAM: Non-Volatile Random Access Memory

P

P: Power

PRP: Parallel Redundancy Protocol

PTP: Precision Time Protocol

R

RTC: Real-time clock

S

SCADA: Supervisory Control And Data Acquisition

SNTP: Simple Network Time Protocol

SSH: Secure Shell

T

TCP: Transmission Control Protocol

U

UR: Universal Relay

URL: Universal Resource Locator

Modification Record

Version	Revision	Date	Change Description
1.00	0	25 th May, 2021	Initial release.