

iBOX* & iBOX Kits

Product Overview

PRPI-043

Version 1.10 Revision 0

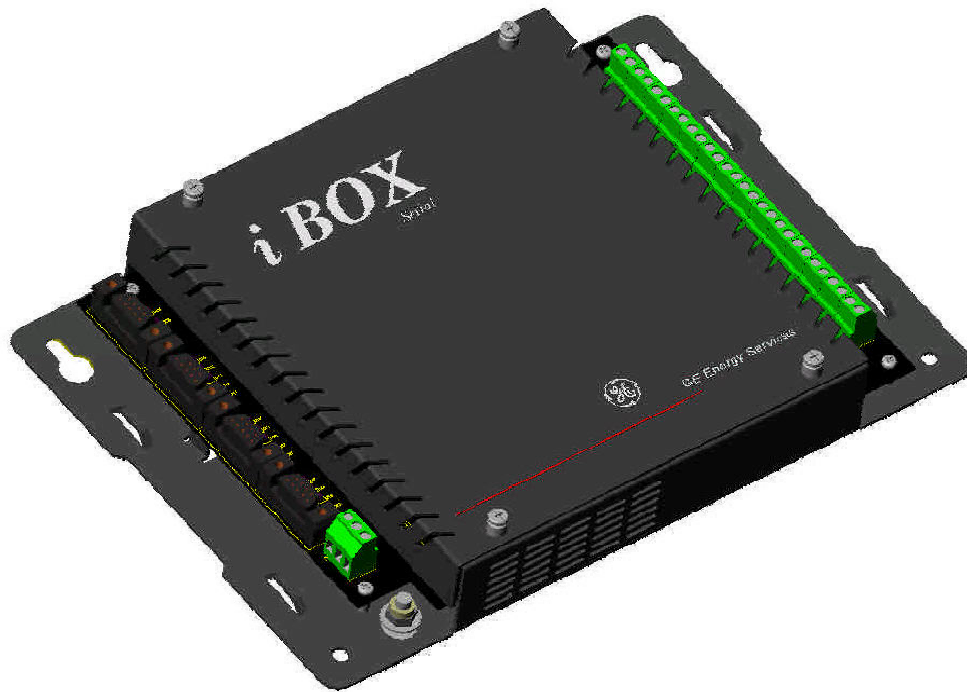

COPYRIGHT NOTICE

© 2005, General Electric Company. All rights reserved.

The information contained in this online publication is the exclusive property of General Electric Company, except as otherwise indicated. You may view, copy and print documents and graphics incorporated in this online publication (the "Documents") subject to the following: (1) the Documents may be used solely for personal, informational, non-commercial purposes; (2) the Documents may not be modified or altered in any way; and (3) General Electric Company withholds permission for making the Documents or any portion thereof accessible via the internet. Except as expressly provided herein, you may not use, copy, print, display, reproduce, publish, license, post, transmit or distribute the Documents in whole or in part without the prior written permission of General Electric Company. The information contained in this online publication is subject to change without notice.

If applicable, any use, modification, reproduction release, performance, display or disclosure of the Product and Associated Material by the U.S. Government shall be governed solely by the terms of the License Agreement and shall be prohibited except to the extent expressly permitted by the terms of the License Agreement.

TRADEMARK NOTICES

GE and  are trademarks and service marks of General Electric Company.

* Trademarks of General Electric Company.

Cooper is a registered trademark of Cooper Industries, Inc. Harris is a registered trademark of Harris Corporation. IEEE is a registered trademark of the Institute of Electrical Electronics Engineers, Inc. ISO is a registered trademark of the International Organization for Standardization. IEC is a registered trademark of the Commission Electrotechnique Internationale. Modbus is a registered trademark of Gould Inc. SEL is a registered trademark of Schweitzer Engineering Laboratories, Inc. Windows is a registered trademark of Microsoft Corporation.

Other company or product names mentioned in this document may be trademarks or registered trademarks of their respective companies.

MODIFICATION RECORD

VERSION	REV.	DATE	AUTHOR	CHANGE DESCRIPTION
1.00	01	Oct 15, 2002	DC	Created
		02.12.18	WP	Check Formatting
1.00	02	Aug 25, 2003	DC	Added detail to the standards levels met Added information on required ferrites to meet CE Mark
		03.09.04	WP	Formatting check
		03.10.28	DC	Added EN61000-4-8 to standards Added NVRAM Retention/Battery Life section
		03.10.31	AV	Updated to GE Power Systems template and checked formatting.
1.10	0	Sept. 29, 2005	D. Cowie	Added iBOX Kits information

Contents

About this Document	6
Purpose.....	6
Additional Documentation.....	6
Product Support.....	7
Search Technical Support	7
Contact Customer Service	7
1. Product Overview	8
iBOX Features	8
iBOX Kit Features	9
2. iBOX Technical Details	11
2.1 Hardware Features	11
2.2 Software Features.....	15
2.3 Communication Capabilities.....	16
3. iBOX Kit Technical Detail	17
3.1 iBOX DC Kit	17
3.2 iBOX AC Kit	18
3.3 DC Analog Inputs	19
3.4 AC Analog Inputs	19
3.5 Power Supply	20
3.6 Ethernet Module.....	20
3.7 Physical Characteristics	20
4. Industrial Standards Compliance	22
5. Ordering Guide	24

Figures

Figure 1 iBOX Kit I/O Options	10
Figure 2 iBOX DC Kit.....	17
Figure 3 Fully equipped iBox DC Kit Block Diagram.....	17
Figure 4 iBOX AC Kit.....	18
Figure 5 Fully equipped iBox AC Kit Block Diagram.....	18

Tables

Table 1 Compliance to Industrial Standards.....	22
Table 2 iBOX Options	24
Table 3 Ferrites Required for CE Mark	24
Table 4 Optional Components	24
Table 5 iBOX Software Overview.....	25
Table 6 iBOX Kit Ordering Guide.....	26

About this Document

Purpose

This document provides a detailed technical overview of the iBOX and iBOX kit.

Additional Documentation

The following documentation is available to provide more detail on the iBOX.

- *iBOX/iBOX Kit Installation and Maintenance Guide (994-0047)*
This user's manual provides details on installing and maintaining the iBOX hardware

Product Support

If you need help with any aspect of your GE Energy product, you have a few options.

Search Technical Support

The GE Energy Web site provides fast access to technical information, such as manuals, release notes and knowledge base topics. Visit us on the Web at:

www.ge.com/energy

Contact Customer Service

The GE Energy Customer Service Center is open 24 hours a day, seven days a week for you to talk directly to a GE representative.

In the U.S. and Canada, call toll-free: 1.800.361.3652

International customers, please call: + 1 540.378.3246

Or e-mail to ge4service@ge.com

1. Product Overview

The iBOX provides powerful yet economical distribution substation and feeder control solutions that combines advanced functionality, multiple communication ports and local I/O in a small footprint ideal for retrofit and upgrade projects.

The iBOX is a low cost, very small I/O point count, small size, panel mount controller intended mainly for substation and feeder applications. It includes eight built-in digital inputs and four control outputs. Three RS-232/485 serial communication ports facilitate communications to master stations and IEDs using GE's extensive communications protocol library.

The iBOX Kit is comprised of a standard iBOX plus the added power of GE approved add-on modules to provide extended functionality. iBOX and add-on devices come pre-configured and integrated, ready for immediate use. In addition to the standard flexibility of the iBOX, the kit provides the added benefits of Ethernet connectivity, AC and DC analog inputs, and support for a wide range of power supply input voltages.

Standalone or as part on an integrated system, the iBOX solution meets utility challenges for:

- Breaker control and monitoring for small distribution substations
- Isolation switch controllers
- Interface to the Hydran* gas analyzer and LTC_MAP* tap changer monitor for entry-level transformer monitoring
- Interface to distribution feeder fault indicators
- Mini data concentrator
- Full featured protocol converter
- Automation platform using standards-based, PLC programming languages
- SCADA interface for pole-top reclosers and sectionalizing switches

iBOX Features

iBOX offers many benefits including:

- Low unit cost makes it affordable to automate more devices leading to improved management of substation equipment and resources.
- Comprehensive protocol library gives flexibility to set up a gateway and data concentration for feeder IEDs, such as switches, reclosers, voltage regulators, revenue meters and capacitor bank controllers.
- Common software applications library with the D20/D25 product families makes it an easy-to-learn addition for existing D20 and D25 users.

- 3 RS-232/485 serial communication ports for master station or IED communications
- Local WESMAINT maintenance port
- Support for IRIG-B Time Synchronization
- Wireless Ethernet-ready via serial PPP interface
- 8 built-in digital input points with 24, 48 and 125 VDC voltage options
- 4 built-in control outputs
- High current carrying capability of control relays eliminates the need for external interposer relays in many cases
- Protection against mis-operation of controls due to single component failure
- Select-before-operate control procedure issues secure and reliable control operations
- Optional LogicLinx* soft logic automation tool smoothly implements popular distribution automation applications, such as capacitor bank control, outage prevention programs and feeder resource optimization
- Windows®-based LogicLinx Editor makes it easy to build, implement and maintain multiple automation algorithms on-line with the iBOX Serial Substation Controller
- Quality product backed by our ISO® 9001: 2000 accreditation

iBOX Kit Features

In addition to all standard iBOX features, iBOX Kits offer these extended benefits:

- Direct AC analog input option enables monitoring of voltage and current without transducers
- LCD display for viewing AC metering values
- Multiple DC Analog input options enable monitoring of a wide variety of transducer outputs
- Ethernet connectivity for easy remote access to information
 - Communicate with multiple master stations over Ethernet
 - Retrieve files, such as fault records, remotely from connected devices
 - Change settings remotely
 - Remotely upgrade configurations to connected devices
 - Access a third-party IED serial port over Ethernet using Virtual Connection software on the iBOX
 - Remote access to SCADA data via the WESMAINT configuration/maintenance port using Telnet over Ethernet
- Wide power supply input range allows easy installation in different environments

Figure 1 provides a summary of the available I/O options for iBOX Kits

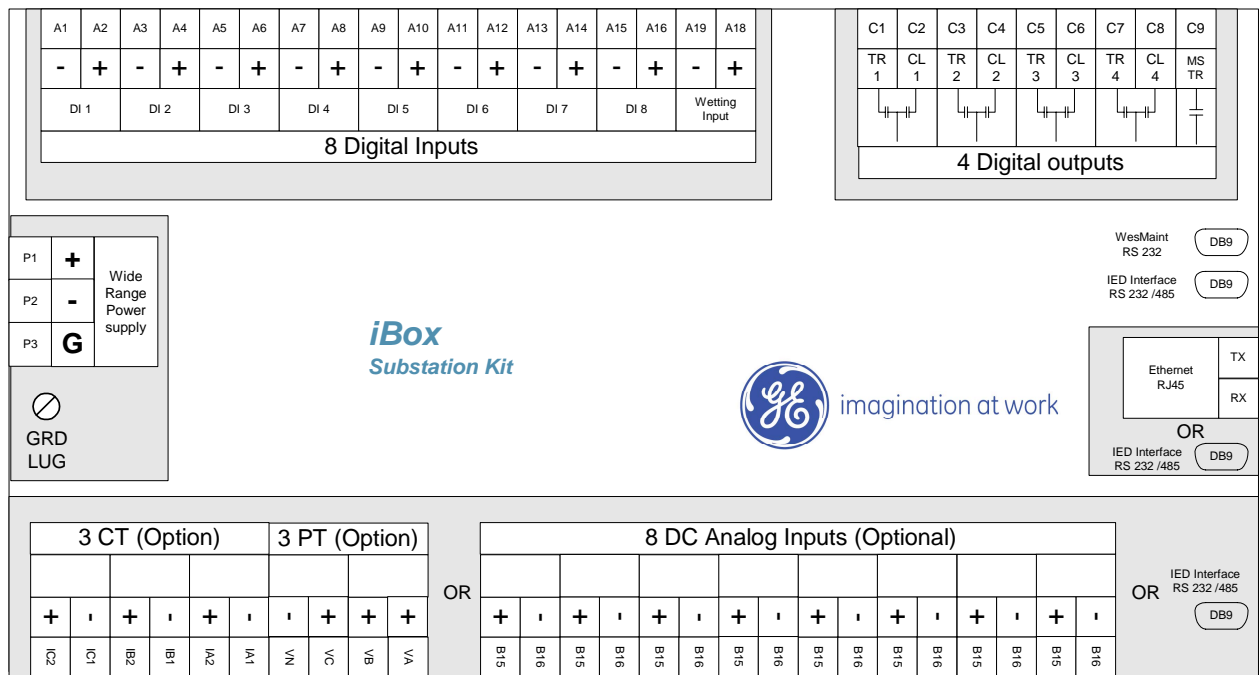

Figure 1 iBOX Kit I/O Options

2. iBOX Technical Details

2.1 Hardware Features

2.1.1 Serial Communications

- Equipped with 3 optically-isolated serial communication ports plus a dedicated WESMAINT local maintenance port
- Each port (except the WESMAINT port) is software configurable for RS-232 or RS-485
- All three serial ports can operate concurrently at up to 38.4kbps
- 500VAC isolation is provided
- DB-9 connectors are used for all serial communications ports
- Immunity protection is provided as outlined in *4. Industrial Standards*.
- Isolated, solid-state Radio keying current sinking output is provided on COM1. This Radio Key relay is driven by the COM1 RTS signal.
- Radio key output is capable of sinking 3 A @ 36 VDC for 100 ms at a 10% duty cycle.
- Complete GE Energy communications protocol library is available for the iBOX

2.1.2 Digital Input Characteristics

- Equipped with 8 optically-isolated Digital Inputs
 - Input voltage options supported:
 - 24 VDC nominal with +/- 20% overload
 - 48 VDC nominal with +/-20% overload
 - 110/125 VDC nominal with +/-20% overload
- Note:** These options cannot be mixed on the same assembly.
- LED indication is provided for each digital input
 - Per point configurable for single or double inputs
 - Per point configurable for Form A, B, C or transition accumulators
 - Digital input accuracy of +/-1 ms
 - First and second-level debouncing and chatter filtering
 - Report limiting for the accumulators
 - Bipolar input signaling capability
 - Digital inputs up to 48 V have an input current burden of typically 4-5 mA per input
 - Digital inputs rated for 125VDC have burden current resulting in max. 0.5 W heat dissipation per input
 - Each digital input has an individual field termination pair accepting an external contact
 - Terminal block position is assigned for the common input signaling voltage source, which must be provided externally. This cannot be generated by the power supply provided on the iBOX.
 - No fuse element for contact wetting external voltages is provided
 - Support 2000V_{AC} dielectric test voltage
 - Immunity protection is provided as outlined in *4. Industrial Standards*.

2.1.3 Digital Output Characteristics

- Support for momentary, pulse train, trip/close and latching operations
- Equipped with either 4 Trip/Close control outputs or 2 Trip/Close control outputs and 2 Form A digital outputs

- DC contact ratings provided for all control output relays:

Power (resistive breaking max.)	180 W @ 30 VDC 35 W @ 150 VDC 750 VA @ 120 VACRMS
Voltage (max.)	125 VDC/120 VACRMS
Current (max.)	6 A (contact interruption capability @30 VDC/120 VACRMS)

- No LED indications are provided
- Digital outputs have two field terminations assigned, providing an isolated Form A contact output for each From A control, or a Trip and Close output for each Trip/Close control
- Terminal position is assigned for the common Trip/Close control voltage source, which must be provided externally
- No fuse element for control output external voltages sources is provided
- Master Close (MC) relay controls the Master Close bus
- Master Trip (MT) relay controls the Master Trip bus
- All relays are momentary, non-latching type relays
- Single Component Failure Protection; no single component failure can cause a false or erroneous control of any coil driver output.
- Control output scheme performs point select relay coil status checks at a rate of no more than the minimum contact closure rate on all control output relays
- Local/Remote switching is provided by an on-board jumper located under the cover. This jumper disables/enables the control output voltage source for the Trip/Close outputs, as well as the control output relay coil voltage for all relays
- Relays can withstand 2000 VAC between coil and contacts
- Immunity protection is provided as outlined in 4. *Industrial Standards*.

2.1.4 Power Supply

- 20-60 VDC input power, allowing for use with nominal 24 VDC and 48 VDC systems
- 2000 VAC isolation between input and outputs
- No On/Off switch is provided
- Short circuit protection
- Reverse polarity protection provided
- Input fuse for protection
- 7 W maximum input supply draw

- Internal power supply cannot be used for status wetting; an external wetting supply must always be used.
- Immunity protection is provided as outlined in *4. Industrial Standards*.

2.1.5 CPU and Memory

- Main processor for the iBOX is the MC68360 QUICC operating at 25 MHz. This allows software code and applications written for the D25 and D20M platforms to be easily ported over and reused.
- Memory is as follows:
 - FLASH: 2 MB
 - NVRAM: 1 MB (configurable by the user as NVRAM, RAM, or some of each)
- NVRAM has a typical retention time of no less than one month
- Background Debug Monitor interface for the MC68360 is provided allowing programming of the Flash and NVRAM memory
- 4 MHz MC68HC11 is used to monitor digital inputs and control digital output operation

2.1.6 NVRAM Retention / Battery Life

The battery in the iBOX can retain the contents of NVRAM for:

- at least 5 years under 0° to 40° C conditions
- at least 10 months under 0° to 70° C conditions
- at least 6 months under the full temperature range –40° to +80° C

The battery has a 10 year life in a normal operational system

2.1.7 Internal Clock

- TCXO clock source is not provided
- One of the serial communication ports can optionally be used as an IRIG-B or Rugby Clock input

2.1.8 Physical Characteristics

Mechanical features of the iBOX are:

- Small size: 7.5" x 11" footprint by 1.75" high
- Panel Mounting: 4 mounting holes, 2 slotted for easy installation
- LEDs are provided to indicate Power On, and CPU Running
- LEDs are provided to indicate the state of communication port lines: Rx, Tx, RTS, CTS, DCD.

- LED is provided to indicate the state of each status point
- Standard DB-9F connectors provided for serial communications
- #14 Compression Terminal Blocks provided for field terminations (status, control and input power)
- Field terminations and connections to communication devices can be made without removing the cover
- All field termination locations are clearly indicated on the PCB
- Power supply input terminations can be easily unplugged to facilitate turning the unit on or off.
- Power supply input fuse is accessible to service personnel by removing the top cover
- Integral #10 ground stud is provided as part of the mounting panel
- Metal electronics enclosure

2.1.9 Environmental

- Operational Temperature: -40° to +80°C
- Storage Temperature: -40° to +90°C
- Humidity: 93% non-condensing at 55°C

2.2 Software Features

2.2.1 Firmware Management

Firmware is stored in FLASH memory allowing for easy firmware change management.

2.2.2 Software Compatibility

iBOX supports the full GE Energy embedded software application library including the following applications:

- DNP3.0
- IEC[®] 870-101
- Modbus[®]
- LogicLinx* soft-logic automation (powerful PLC type logic) Configuration Management

2.2.3 Configuration Tools

Software configuration is managed using GE's ConfigPro* configuration management tool. ConfigPro 6 or newer is recommended for iBOX device management.

Windows®-based LogicLinx Editor makes it easy to build, implement and maintain multiple automation algorithms on-line with the iBOX.

2.3 Communication Capabilities

2.3.1 Serial Communications

The RS-232/485 serial ports provide protocol conversion for information exchange between multiple Master Stations and IEDs. The serial ports operate independently, supporting data rates up to 38400 bps.

2.3.2 Local Maintenance Port

The WESMAINT configuration/maintenance port provides a local, VT-100 based human-machine interface to the iBOX.

2.3.3 IRIG-B Time Synchronization

IRIG-B is an industry standard timing protocol that uses serial or fiber optic cable to distribute the timing signal. IRIG-B signals can be received by an iBOX using one of the serial ports.

2.3.4 Ethernet Ready

iBOX supports IP connections to devices that support PPP (Point-to-Point Protocol) serial connections. PPP is the same protocol used to connect home PCs to the Internet using dial-up modems, and is supported by various types of communication equipment including wireless Ethernet radios.

A full IP stack runs on the iBOX allowing multiple IP connections simultaneously over a single serial port. For example, DNP, IEC-101, and Telnet to WESMAINT connections can all occur simultaneously over a single PPP link into an RS-232 port. An optional add-on module to provide a physical 10/100BaseT connection is available as part of an iBOX Kit.

3. iBOX Kit Technical Detail

The iBOX Kit is comprised of a standard iBOX and GE selected third-party add-on modules to provide extended functionality.

3.1 iBOX DC Kit

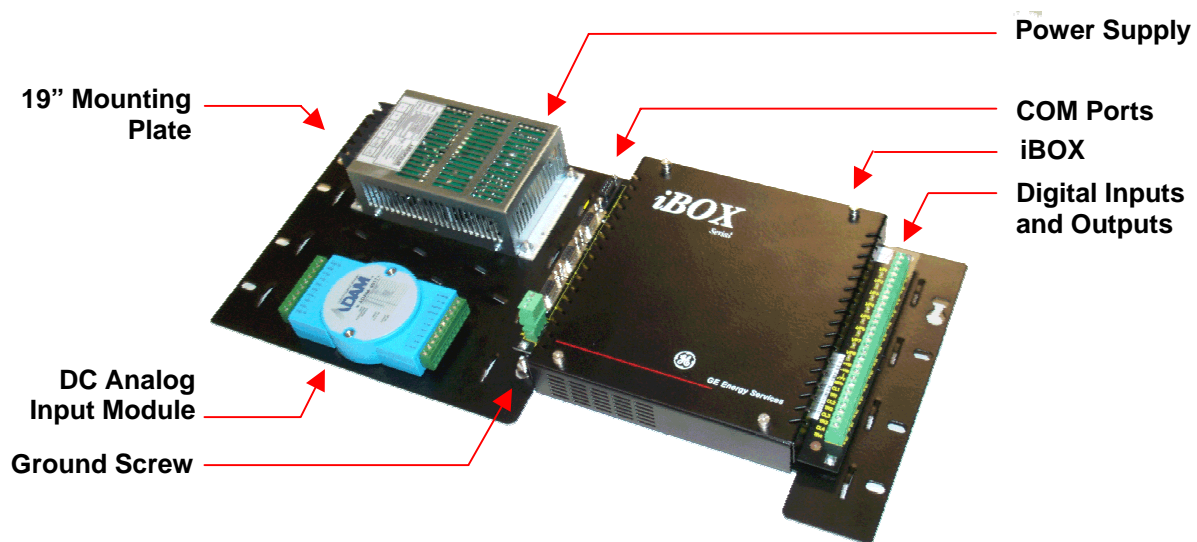

Figure 2 iBOX DC Kit

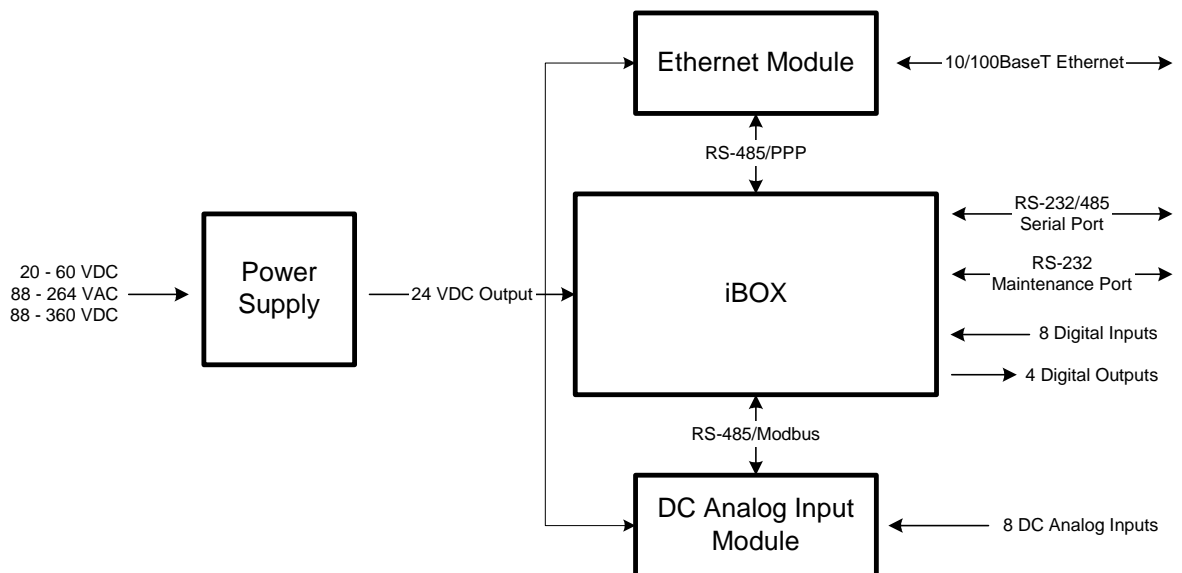

Figure 3 Fully equipped iBox DC Kit Block Diagram

3.2 iBOX AC Kit

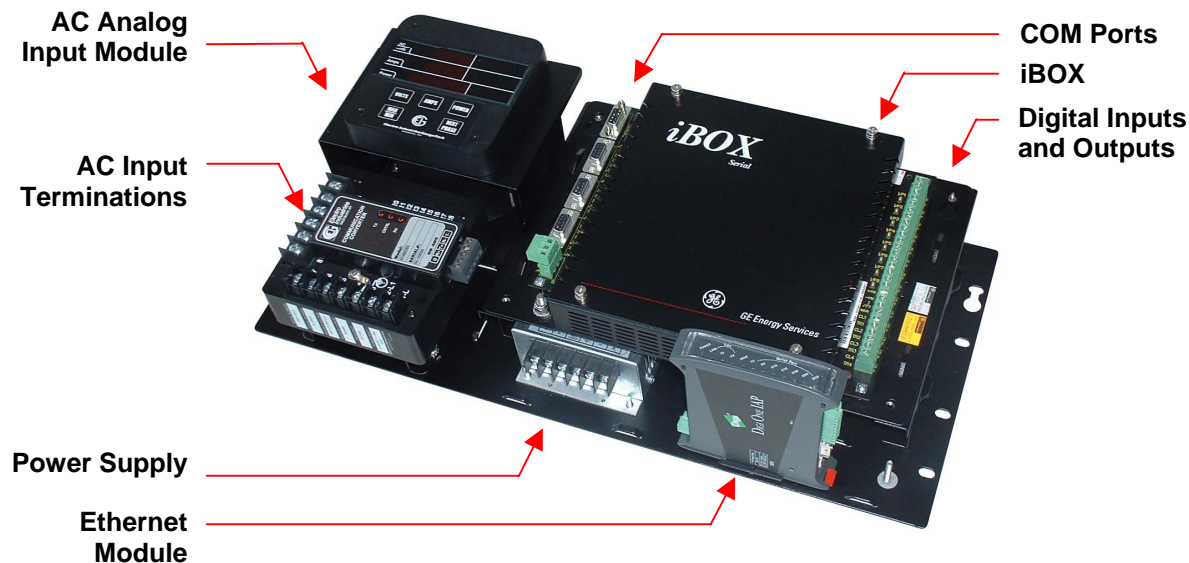

Figure 4 iBOX AC Kit

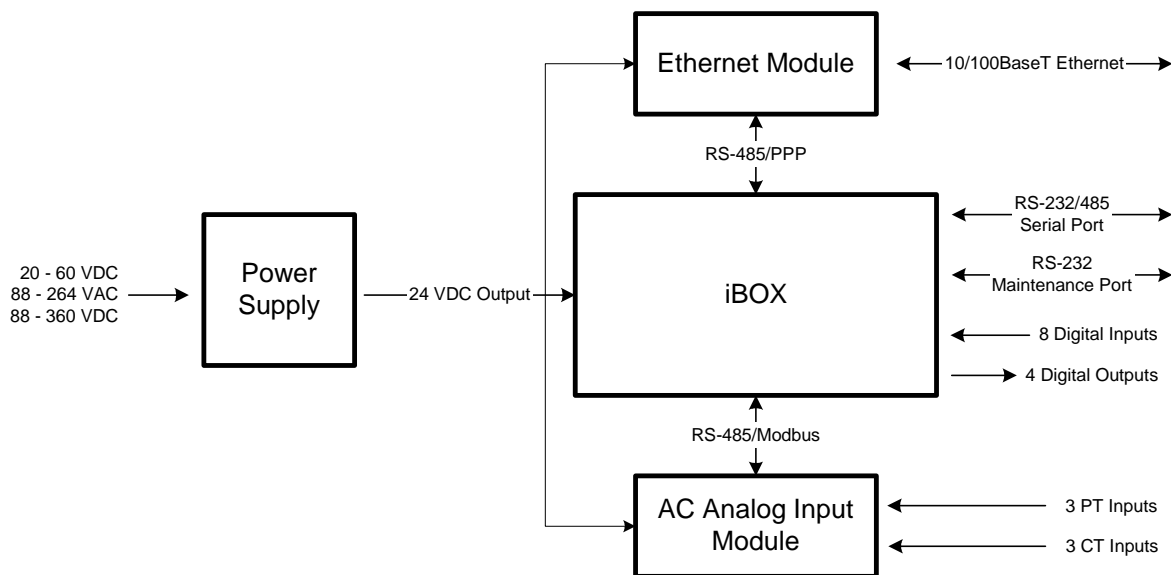

Figure 5 Fully equipped iBox AC Kit Block Diagram

3.3 DC Analog Inputs

- 8 DC analog inputs
- DC voltage options: +/- 1 VDC, +/-5 VDC, +/-10 VDC
- DC current options: +/-1 mA, +/-20 mA, 4-20 mA
- Accuracy: 0.2% of full scale @ 25°C
- 14-bit resolution, plus sign

3.4 AC Analog Inputs

- 3 PTs and 3 CTs for direct measurement of 3-phase voltage, current and power on a single circuit
- LCD display for AC values
- Standard analog input configuration is 3-element wye, 120/208 VAC, 5 A.
- V_{RMS} , I_{RMS} , Phase Angle, Frequency, Power Factor
- Real Power (W), Reactive Power (VAR), Apparent Power (VA)
- Watt-Hour, VAR-Hour
- Nominal PT input range: 0 to 150 VLN or 250 VLL
- Frequency: 50/60 Hz
- Measurement range: 0 to 125% of nominal
- Accuracy: 0.3%
- Continuous overload withstand: 200% of nominal
- Short duration overload withstand: 100 A for 3 s
- Surge Withstand as per IEEE[®] C37.90.1, ANSIC62.41
- True RMS sampling at 64 samples per cycle
- Isolation: 2500 VAC/60 Hz
- Burden:
 - Voltage & Current: 0.1 VA max
 - Power Supply: 6 VA max

3.5 Power Supply

The Power Supply module provides regulated 24 VDC power for all the modules included in the iBOX Kit, optional 24 VDC status wetting, and optional power for one additional piece of communications equipment provided by the customer, such as a modem or fibre optic converter.

- Input options: 20–60 VDC or 88-264 VAC/88-360 VDC
- Output: 24 VDC
- 20 W max input supply draw

3.6 Ethernet Module

The optional Ethernet module provides a single Ethernet channel using 10/100BaseT (Unshielded twisted pair wire, RJ-type connection).

3.7 Physical Characteristics

The iBOX Kit comes in two mechanical layouts, one for DC analog inputs and one for AC analog inputs.

3.7.1 Dimensions

- DC Kit: 8.75" x 19" footprint
 - 2" high without Ethernet
 - 4.9" high with Ethernet
- AC Kit: 8.75" x 19" footprint
 - 4.7" high without Ethernet
 - 4.9" high with Ethernet

3.7.2 Mounting

- 4 mounting holes, 2 slotted for easy installation
- Integral #10 ground stud is provided as part of the mounting panel

3.7.3 Terminations

- Digital Inputs: #14 quick-disconnect compression terminal blocks
- Controls: #14 quick-disconnect compression terminal blocks
- DC analogs: #14-quick disconnect compression terminal blocks
- AC analog: barrier strip
- Input power: barrier strip

3.7.4 Environmental

- Temperature:
 - iBOX: -40° to +80°C operating range
 - DC Analog Module: -10° to +70°C operating range
 - AC Analog Module: -20° to +70°C operating range
 - Ethernet Module: 0° to +60°C operating range
 - Power Supply: -40° to +80°C operating range

4. Industrial Standards Compliance

iBOX meets demanding international engineering standards, including IEC, CE Mark, and North American IEEE® impulse and surge standards. Our ISO® 9001 accreditation confirms our commitment to quality.

Note: All tests were completed with clamp on cable ferrites installed on all I/O wiring and coms cables. Clamp-on cable ferrites are required for CE Mark. Ferrites are not required in non-CE countries.

Note: The following table reflects compliance levels for the iBOX product only. The third-party add on modules used as part of iBOX Kits are not covered in the following tables.

Table 1 Compliance to Industrial Standards

Standard	Description	Level
EN55011	Limits and methods of measurement of electromagnetic disturbance characteristics of industrial, scientific and medical (ISM) radio-frequency equipment.	Class A
EN60255-5	Dielectric Test Impulse Voltage Test Insulation Resistance	2 kV 5 kV >100 Mohm
EN61000-4-2	Electrostatic Discharge Immunity Test	Contact: 8 kV Air: 15 kV Level 4
EN61000-4-3	Radiated, radio-frequency, electromagnetic field immunity Test	10 V/m, Level 3
EN61000-4-4	Electrical Fast Transient/Burst Immunity Test	Power Supply: 4 kV @2.5 kHz, Level 4 I/O: 2 kV @5 kHz, Level 3 Coms: 2 kV @5 kHz, Level 3
EN61000-4-5	Surge Immunity Test	4 kV, Level 4
EN61000-4-6	Immunity to conducted disturbances induced by radio-frequency fields	10 Vrms, Level 3
EN61000-4-8	Power Frequency Magnetic Field	300 A/m continuous 1000 A/m for 3 seconds Level 5
EN 61000-4-12	Ring Wave Immunity Test (100 kHz)	4 kV, Level 4
EN61000-4-16	Test for Immunity to Conducted, Common Mode Disturbances in the Frequency Range 0 Hz to 150 kHz (steady state frequency)	30 V for 30 s 300 V for 1 s

Standard	Description	Level
EN 61010-1	Safety Requirements for Electrical Equipment for Measurement, Control and Laboratory Use – General Requirements	Over-voltage Category 2
IEC 68-2-1	Cold	-40°C, 96 hours
IEC 68-2-2	Dry heat	80°C, 96 hours
IEC 68-2-6	Vibration	10-150 Hz @ 1g
IEC 68-2-30	Damp heat, cyclic (12+12-hour cycle)	+55°C, 93+/-3% RH, non-condensing, 6 cycles
IEC 68-2-31	Drop and topple	50 mm
IEEE C37.90.1-1989	SWC capability	2.5 kV for SWC 4-5 kV for Fast Transient
IEC 60529	IP20 Rating: Protected against solid objects up to 12 mm (including fingers). No protection against liquids.	IP20

5. Ordering Guide

5.1.1 iBOX Ordering Guide

iBOX is available in the following hardware configurations.

Table 2 iBOX Options

Part Number	Description
505-0100	iBOX, 8 Digital Input (24V) & 4 Trip/Close Control Output
505-0101	iBOX, 8 Digital Input (48V) & 4 Trip/Close Control Output
505-0102	iBOX, 8 Digital Input (110/125V) & 4 Trip/Close Control Output
505-0103	iBOX, 8 Digital Input (24V) & 2 T/C & 2 Form A Control Output
505-0104	iBOX, 8 Digital Input (48V) & 2 T/C & 2 Form A Control Output
505-0105	iBOX, 8 Digital Input (110/125V) & 2 T/C & 2 Form A Control Output

Clamp-on cable ferrites are required for CE Mark. Ferrites are not required in non-CE countries

Table 3 Ferrites Required for CE Mark

Part Number	Comments
460-0049 (order 7)	Clamp-on cable ferrites are required on all I/O wiring and communications cables for CE Mark. Ferrites are not required in non-CE countries. 7 ferrites are required: 1 on each of the three communications cables, 2 for the digital inputs, and 2 for the controls.

When ordering iBOX, consider the following items to ensure you get everything you need.

Table 4 Optional Components

Option	Comments
Power Supply	iBOX requires 20 – 60 VDC input power & external DI wetting. External communication equipment (e.g. Modems) also needs separate power supply.
Modems	iBOX has hardware support for standard modem lines (RTS, CTS, DCD, TX, RX)
RS-485 Conv	iBOX has built-in support for RS-232 and RS-485, converters are not required
Coms Cables	Communication cables are not included with the iBOX Main Assembly
WESMAINT Cable	Local maintenance interface requires a WESMAINT cable
Interposer Relays	iBOX controls: 35 W breaking @ 150 VDC, 180 W breaking @ 30 VDC, 6 A current carrying. Higher loads will require the use of additional interposer relays
Cabinet	Separate enclosure is required to protect the iBOX from the elements
Data Display Panel	The D20 Data Display Panel is compatible with the iBOX. The panel is connected via one of the serial ports, and must be mounted separately.

Table 5 iBOX Software Overview

Software Type	Comments
Firmware	<p>A standard firmware set is included with the iBOX at no additional cost. For orders requiring a custom firmware integration, integration fees, and license fees will be applied. The Standard iBOX Firmware set includes the following applications:</p> <ul style="list-style-type: none"> • IEC®-870-5-101/104 DPA • DNP3.0 DPA • DNP3.0 DCA • Modbus DPA • Modbus DCA • Syprotec Hydran DCA • Harley* LTC-MAP DCA • Harris® 6000 DPA • Harris 6000 DCA • Cooper® 2179 DCA • SEL® DCA • 8979 DPA • LogicLinx Executor (powerful PLC type logic)¹ • Calculator DTA • SOE Logger DTA • Communication Watchdog DTA • Accumulator Freeze DTA • Virtual Terminal DTA • Mailbox DTA • Irig-B DTA • ProLogic* DTA • Analog Reference DTA • Base System (system point database, local user interface, system services, ...) • Plant I/O DCA (iBOX physical I/O collection) <p>¹ A separate license fee is charged for the Windows®-based LogicLinx Editor required to program the logic in LogicLinx.</p> <p>If the standard firmware set does not contain the applications required for a particular project then custom firmware sets can be created, at an additional cost, from the entire GE Energy application library.</p> <p>For demonstration purposes, the standard firmware set will be included.</p>
Configuration	<p>Default iBOX and iBOX Kit configurations are included with the iBOX at no additional cost. If a custom configuration is required, standard custom configuration fees will be applied.</p>
ConfigPro	<p>ConfigPro 6 with the appropriate application definitions is required to configure the iBOX.</p>
LogicLinx Editor	<p>Windows-based LogicLinx Editor. Only required if LogicLinx functionality is required.</p>

5.1.2 iBOX Kit Ordering Guide

iBOX Kits are ordered using a configured item number as outlined below.

Table 6 iBOX Kit Ordering Guide

iBOX Kit-	*	*	*	*	*	*
iBOX OPTIONS						
(1) - 24V DIGITAL INPUT & 4 TRIP/CLOSE CONTROL OUTPUT	1					
(2) - 48V DIGITAL INPUT & 4 TRIP/CLOSE CONTROL OUTPUT	2					
(3) - 125V DIGITAL INPUT & 4 TRIP/CLOSE CONTROL OUTPUT	3					
(4) - 24V DIGITAL INPUT & 2 T/C & 2 FORM A CONTROL OUTPUT	4					
(5) - 48V DIGITAL INPUT & 2 T/C & 2 FORM A CONTROL OUTPUT	5					
(6) - 125V DIGITAL INPUT & 2 T/C & 2 FORM A CONTROL OUTPUT	6					
iBOX POWER SUPPLY OPTIONS						
(A) - 20-60 VDC Input, 24VDC Output		A				
(B) - 88-264VAC/88-360VDC Input, 24VDC Output		B				
iBOX ETHERNET OPTIONS						
(U) - No Ethernet Required			U			
(A) - 10/100 BaseT Ethernet Module			A			
iBOX ANALOG OPTIONS						
(U) – None				U		
(A) - AC Analogs 3PT, 3CT (120VAC, 5A, Wye)				A		
(B) - 8 DC Analogs (+/-1V)				B		
(C) - 8 DC Analogs (+/-5V)				C		
(D) - 8 DC Analogs (+/-10V)				D		
(E) - 8 DC Analogs (+/-20mA)				E		
(F) - 8 DC Analogs (4-20mA)				F		
(G) - 8 DC Analogs (+/- 1mA)				G		
iBOX MOUNTING OPTIONS						
(A) - Panel Mount - DC Analog Kit					A	
(B) - Panel Mount - AC Analog Kit					B	
iBOX PRODUCT DOCUMENTATION						
(U) – None						U
(B) - iBOX Product Information CD						B

Additional options available on request include:

- Outdoor cabinets
- Modems (Leased-Line, Dial-up)
- Radios
- Batteries and Chargers

