

MiCOM Agile P842

Mesh Corner Auto-reclose Relay

GE's MiCOM Agile P842 is a cutting edge solution for the automatic reclosure of circuit-breakers, the automatic isolation of persistently faulted plants and the suppression of ferroresonance following a fault in the system.

The MiCOM Agile P842 Mesh Corner Reclose Unit (MCU) uses high-speed peer to peer communications over Ethernet to provide a flexible, distributed scheme for the delayed auto-reclose (DAR) and auto-isolation of a mesh bus station.

Equipment is provided on the basis of one MCU per mesh corner. Although each MCU is an autonomous unit, inter-unit communications ensures the co-ordinated control of a complete mesh system. Inter-unit communications can be made via Ethernet peer to peer communications or as a traditional hardwired link. A typical single switch system would require two MCUs, a two switch system - three MCUs, and three and four switch systems - four MCUs.

The P842 provides integrated system check functions for up to two controlled circuit-breakers. Two check sync stages are provided that can be used for check sync and system sync closure, together with detection of a system split condition. The P842 is designed using the standard hardware and software platform.

Programmable scheme logic (PSL) is provided to assist with the flexible application of the MCU for different plant topologies.



Key Benefits

- Faulted electrical plants isolated for permanent faults
- Flexibility for different busbar arrangements
- System checks plus ferroresonance suppression
- UCA2 GOOSE peer to peer communications in real time
- Splitting into functional groups allows easy commissioning and 'fault-finding'



Application

The MiCOM Agile P842 is highly flexible and will accommodate most mesh corner plant configurations. The P842 is designed for automatic and manual switching of complete substation configurations and does not include any protection functions.

The P842 can be applied for automatic switching to:

- Single switch systems
- 2 switch systems
- 3 switch systems
- 4 switch meshes

Other configurations can also be accommodated.

Key Features

The relay provides the following main features:

- Flexible configuration
- DAR (Delayed AutoReclose in 3-pole tripping applications)
- System checks
- Auto-isolation
- Ferroresonance suppression
- Peer to peer communications
- PSL (programmable scheme logic)
- Comprehensive diagnostics and commissioning aids

Control Functions

Control Functions	Description
Circuit-breaker function	Up to 2 directly controlled breakers
Feeder function	Up to 2 feeders connected to the mesh corner
Transformer function	Up to 3 banked transformers
Ferroresonance suppression	Control up to three banked transformer isolators to suppress resonance
System checks	2 stages of sync check including system split alarm
DAR interlocking	Trip relay reset
Peer to peer communications	Real-time GOOSE messaging for up to 32 relays

Ancilliary Functions

Ancilliary Functions	Description
Measurements	4 voltage inputs
Event records	500 events
Disturbance records	4 analogue and 32 digital signals
Rear port communications	Courier or IEC 60870-5-103



Mesh Corner Function

Accepts inputs from the mesh corner bus protection (DAR required/DAR not required).

Feeder Function

Accepts inputs from the feeder protection (DAR required/DAR not required and intertrip) and controls auto-isolation of the feeder.

Transformer Function

Accepts inputs from the transformer protection (DAR not required) and controls auto-isolation of the transformer.

Circuit Breaker Function

Monitors status of the circuit-breaker (CB). Operates in response to other control functions to perform delayed auto-reclose of the CB. Direct control of up to two breakers is provided.

System Checks

Accepts analogue voltage inputs from an external voltage selection scheme. Provides information to the CB function to allow dead line, bus or checksync closure of up to two CBs. Two stages of check sync are provided in addition to a system split alarm.

Ferro-resonance Suppression

Accepts inputs from an external ferroresonance detector. Raises an alarm and performs suppression of the ferroresonance condition by the flapping of the transformer disconnecter(s).

DAR linterlocking

The trip relay reset is controlled to co-ordinate the DAR at the local and remote ends of the feeder.

Peer-to-peer Communications

UCA2 GOOSE messaging over RJ-45 copper or 10 Mbit/100 Mbit fibre Ethernet connection allows logic signals to be passed between up to 32 units in real-time. GOOSE implementation increases the scheme flexibility, reduces the need for physical wiring and consequently reduces the associated costs.

Information Interfaces

Information exchange is done via the local control panel, the PC interface and optional rear communications interface.

The communications interface conforms to IEC 60870-5-103 or Courier and is intended for integration with substation control systems.

Functional Overview

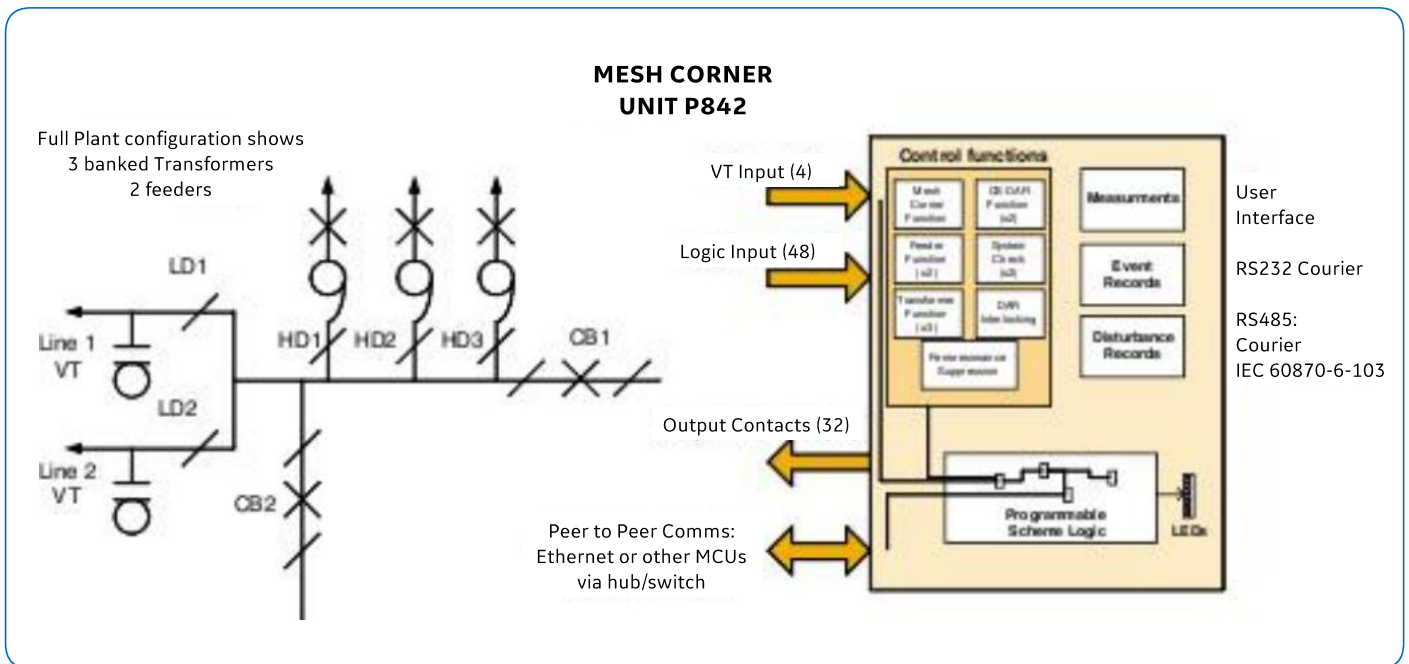

Track Record - Mesh Corner Autoreclose Relay

LFAA103:

First digital mesh corner autoreclose device launched in 1989.
More than 230 devices installed.

MiCOM Agile P842:

LFAA103 functionality implemented in MiCOM P40 Agile series
range since 2002. More than 40 devices installed.

LFAA103:

First digital mesh corner autoreclose device launched in 1989.
More than 230 devices installed.

About MiCOM P40 Agile

GE's philosophy is one of continuous improvement in our products and solutions. Our emphasis on communications in MiCOM has become a focus which secures our leadership in digital substations. To mark this phase of evolution, the brand "P40 Agile" is applied to the range. The P40 Agile is a mark of performance and quality, only available from GE.

For more information please contact
GE Power
Grid Solutions

Worldwide Contact Center

Web: www.GEGridSolutions.com/contact
Phone: +44 (0) 1785 250 070

GEGridSolutions.com

IEC is a registered trademark of Commission Electrotechnique Internationale. IEEE is a registered trademark of the Institute of Electrical Electronics Engineers, Inc.

GE and the GE monogram are trademarks of General Electric Company.

GE reserves the right to make changes to specifications of products described at any time without notice and without obligation to notify any person of such changes.

P842-Brochure-EN-2018-10-Grid-GA-0716. © Copyright 2018, General Electric Company.
All rights reserved.



Imagination at work